

driven
by knowledge

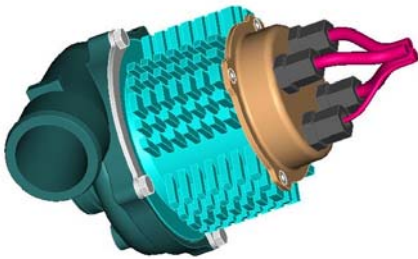

Dr. S. Münz¹, Dr. M. Schier², H. P. Schmalzl¹, Dr. Th. Bertolini²

eBooster

Design and performance of a
innovative electrically driven
charging system

Academy



¹ BorgWarner Turbo Systems GmbH
Marnheimer Straße 85/87
67292 Kirchheimbolanden

² ebm Werke GmbH & Co.KG
Bachmühle 2
74671 Muldingen



BorgWarner
Turbo Systems

1. Introduction

A result of the combustion of fuels obtained from fossil fuel deposits is an increase in the concentration of carbon dioxide in the atmosphere. It has been proven that this contributes in a substantial manner to a change in the radiation balance of the Earth with the associated effects on the global climate. Furthermore, oil is an important resource in many areas of human activity and the amount of oil that is available in economically extractable deposits is limited. In the year 2000, the worldwide confirmed crude oil reserves that can be economically exploited using today's technology is 139,707 million tons with a worldwide production of 3354.8 million tons. Although production increased between 1999 and 2000 by 3.7%, the crude oil reserves could only be increased by 1.2% [1]. From today's point of view, the economically exploitable crude oil reserves are sufficient for several decades and possibly beyond the year 2050 [11] if the appropriate measures are taken. This problem urges us to reduce consumption as well as to reduce the emissions of combustion products as much as possible. Since carbon dioxide is an end product of complete combustion, a reduction in the fuel consumption is synonymous with a reduction in CO₂ emissions.

In Germany in the year 2000, driven by the replacements of older vehicles by vehicles with redesigned, lower consumption engines, by the increase in the percentage of diesel automobiles and, last but not least, by a change in attitude of the end customers, 4.3% less gasoline was sold than in the year before. Sales of diesel fuel in this period only increased by 0.3% for the reasons stated above, although the increase was partially compensated for by engines with lower fuel consumption [1]. This change in Germany, which is a positive change in terms of environment protection, is not representative for the situation worldwide.

In this context, though, the obligation made by the European Automobile Manufacturers Association to reduce the average carbon dioxide emissions to 140 g CO₂ / km by the year 2008 represents a major contribution. 140 g CO₂ / km means a fuel consumption of 6.0 l / 100 km for gasoline engines and of 5.3 l / 100 km for diesel engines. Compared to the situation today, the decision of the automobile manufacturers and suppliers represents a great challenge.

A pioneering innovation is the reduction of the displacement of the combustion engine and a reduction in the number of cylinders. This innovation has definite advantages in terms of fuel efficiency and emissions. The advantage for the customer over a larger displacement engine, in addition to a reduction in mechanical losses, was gained because the motor is operated closer to its design point more often on average, i.e. closer to its operating point of optimum efficiency. At least from the point of view of the end customer the demand for driving performance and driving comfort will stay the same. This means that the displacement can be reduced, but only if the characteristics - steady-state and transient - of the large displacement engine are maintained. However, the torque produced by a small engine is pronouncedly less than that of a large engine at low engine speeds. One solution for compensating for the lower torque is the use of a suitable, high-performance charging system in conjunction with other measures.

2. Motivation behind electrically driven charging systems

While only the performance in the upper engine speed ranges can be positively influenced with unregulated turbochargers, the integration of a bypass unit (waste gate) in the turbocharger permitted the design to be a compromise between performance in the rated range and high torque in the middle speed range (taking the mechanical boundary conditions of the engine and turbocharger into account). After all, this integrated design is the basic prerequisite for the success of the turbocharger as a standard turbocharging unit today.

Additional improvements in the dynamics of the combustion engine while simultaneously reducing the exhaust back-pressure were achieved through the introduction of variable geometries on the turbine intake. While this type of charger is increasingly replacing chargers with simpler bypass valves in diesel engines and is considered to be the standard charging device for diesel engines, the waste gate turbocharger is still the state of the art for production gasoline engines due to the high exhaust temperatures of up to 1050°C.

An interesting way to significantly improve the steady-state and transient performance characteristics is to connect two differently sized turbochargers in series with integrated measures to regulate the system, also referred to as "RS2" two-stage regulated charging by BorgWarner Turbo Systems [2], [3], [4].

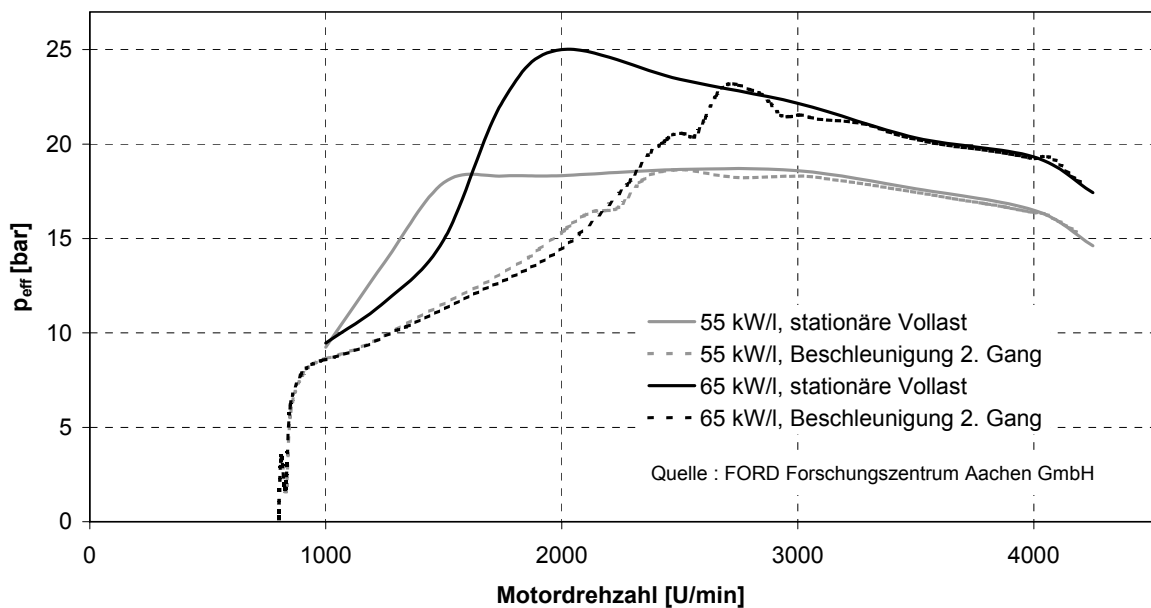

Figure 1: Comparison of the steady-state and transient torque curves for various specific outputs

The successful implementation of the downsizing concept with appealing driving performance in both the steady-state and transient operating phases is inseparably connected to a high degree of engine charging in addition to other measures. It also requires the charging system to be very effective in transient operating phases, even in the lowest speed range, in order to obtain a high starting torque and appealing acceleration characteristics. The advantages of the exhaust turbocharger over the other operating principles are attained through the purely thermodynamic coupling of the turbocharger and combustion engine. However, these advantages come with the disadvantage that the ability of the charger to fulfill its function, whether with a fixed or variable geometry, is completely dependent on the mass flow rate and the thermodynamic system parameters of the exhaust gas.

To more clearly demonstrate this fact, Figure 1 graphs the effective middle pressure of modern diesel engines against the engine speed for various specific outputs, i.e. for an increasing degree of charging. It becomes clear that the discrepancy between the steady-state and transient response becomes greater with increasing per liter output even with optimized motor and charger designs, i.e. when the vehicle is accelerated, the steady-state full-capacity curve is reached at increasingly higher engine speeds as the per liter output increases. Currently, this discrepancy can only be overcome using additional charging [5] in which the drive energy is independent from the operating state of the combustion engine.

Since mechanically driven auxiliary units need some of the extra energy supplied for their own drive due to their link to the crankshaft, their potential is limited. Hydraulically driven systems require an accumulator with the corresponding pump. This variant is still problematic in spite of the high power density of the hydromotor in terms of availability (speed and response) and the increasing tendency to reduce the size of the oil system. Due to its basic availability in the vehicle and the known capabilities for producing, storing and routing of electrical energy, the concept of supplying electrical power to the drive of the additional charging unit is an important implementation concept.

It must be remembered that the development of an electrically driven charging system must match the capabilities and remain within the limits of the electrical vehicle electrical system. Since the introduction of a 42 V vehicle electrical system with an increased capacity has been delayed for various reasons and, when introduced in production models, will probably be seen first in the top class of vehicles, most effort has been concentrated on a modified and higher performance 12 V vehicle electrical system. However, this development work is not only being promoted rapidly for its potential use for electrically driven charging devices, but also for other electricity-consuming devices as well. If you take a look at the capacity of vehicle electrical systems today and reflect on the new capabilities of a 12V-based system, then it becomes clear that electrical power support primarily only comes into question for the transient operating states of the combustion engine. This is due to the electrical output required for the charging device, the additional output available from the vehicle electrical system and the load on the vehicle electrical system.

3. Ways of providing additional electrical power for charging

Various ways of providing the additional electrical power and accomplishing the charging have been suggested and engineered. These include machines based on the displacement or flow principle, for example, which utilize the impulse of the flowing column of gas.

One way to provide electrical support for turbocharging is by integrating an electric motor into the turbocharger shaft, for example between the turbine and compressor impellers (Figure 2). The length of this type of charger, which is generally called an eu-ATL or EAT, is only a little longer (about 25 mm longer) than a corresponding standard turbocharger. In addition to the electric motor, another component, the control and power electronics, must also be added. The electronics, however, need to be placed separately at a suitable location due to the thermal load from the hot exhaust gases flowing through the turbine and the mechanical load from the operation of the combustion engine. A goal of this development is to demonstrate this type of charger with integrated electronics, but to date there has been no report of an exhaust turbocharger with an integrated motor and integrated power electronics.

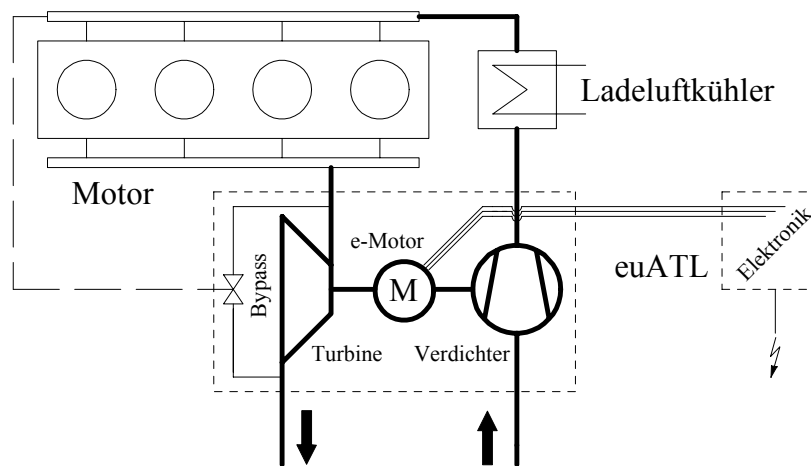

Figure 2: Diagram of the electrically driven exhaust turbocharger

This charger provides a noticeably improved transient response at operating points in which there is not much exhaust gas available due to the integration of the electrical rotors in spite of the increase in the mass moment of inertia of the rotating blades [6]. The potential for improvement in the transient operating characteristics depends primarily on the amount of electrical power available and the electrical infrastructure of the vehicle. Improvements in the steady-state characteristics are limited, though, since the operating points must lie within the given compressor map limits due to being a system with single stage process management. However, with the extra electrical power, i.e. by providing additional power when in transient driving states, the steady-state limits of the map are transiently but quickly reached.

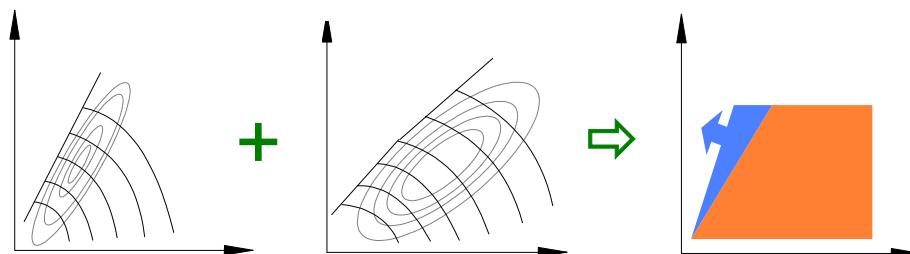

Figure 3: Expansion of the power curve (diagram)

This type of charger can also operate as a generator, although it still needs to be clarified whether or not the possible use of this energy is technically and economically feasible in the automobile industry. For the utility vehicles, though, this potential raises interest since the eu-ATL also provides a contribution to the motor braking performance [9], [10]. When operating as a generator, the electric motor brakes the rotors of the turbocharger and feeds this braking power, reduced in accordance with the efficiency chain, to an accumulator. Due to the comparatively high amount of electrical output when operating near the design point of the combustion engine, the accumulator quickly reaches a completely charged state, although a waste gate must be used in this case for the charger.

Besides the comparatively high thermomechanical load of the electric motor as an integrated component of the turbocharger – the electric motor must cover the entire operating range of a standard turbocharger even when it is not active itself – voltages are induced on the shaft even when the electric motor is not operating when a synchronous motor with permanent

magnets is used. This has a negative effect on the operation of the turbocharger. Based on the results of a comparative system study, emphasis is being placed on pursuing another electrically driven charging system at BorgWarner Turbo Systems due to its advantages [2], [8] :

This system is based on the use of a flow compressor driven by an electric motor and is called the "eBooster" by BorgWarner Turbo Systems. The component is designed to be placed before or after a standard turbocharger (Figure 4, Figure 5). In contrast to electrically driven turbochargers, it operates as a two-stage system of two turbomachines connected in series, i.e. the pressure ratios of the two charging units are multiplied. Through the use of two flow compressors it is possible to match the two units and/or to optimize them for the particular application and expand the power curve of the charging system (Figure 3), which also is of particular interest for providing extra steady-state electrical power. The eBooster and exhaust turbocharger represent separate units connected by hoses. This results in additional advantages since the electrical and electronic components are smaller than for the electrically driven charger when the thermomechanical load is positioned similarly. It is possible without too much effort to integrate the power and control, which would yield advantages in terms of the electromagnetic compatibility. If the cooling system cannot be used or there is not enough space, this challenge could still be solved using alternative schemes.

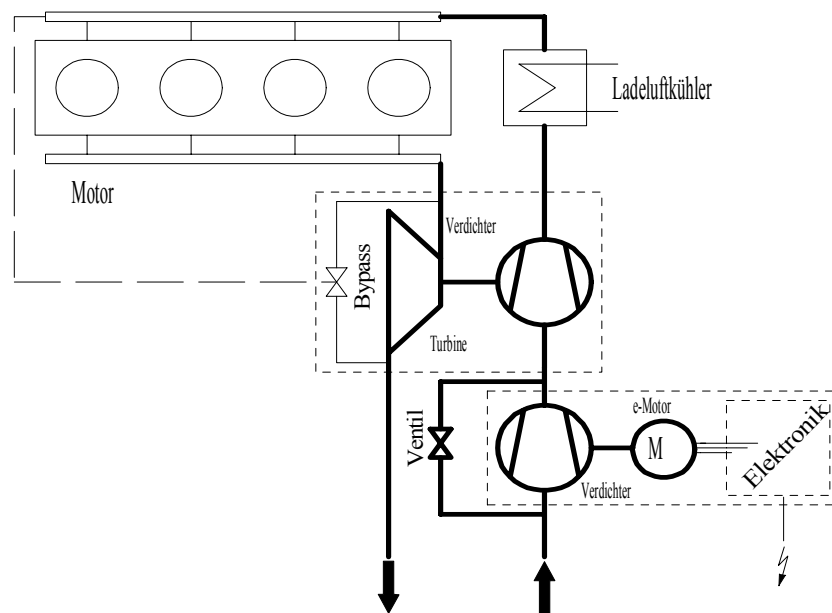

Figure 4: eBooster charging system, eBooster before the turbocharger

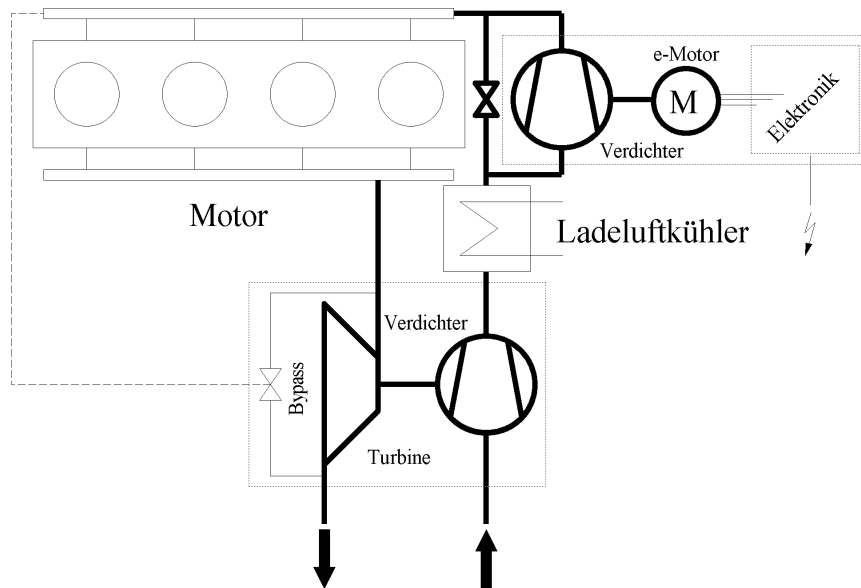

Figure 5: eBooster charging system, eBooster after the turbocharger

In general, it is possible to position the eBooster before or after the exhaust turbocharger directly on the suction pipe. In terms of the mechanical load, mounting the unit on the vehicle chassis is advantageous, although even when mounted on the motor a certain amount of decoupling can be achieved using suitable intermediate elements. The system is rounded off by a bypass with an actively or passively activated valve that redirects at least most of the combustion air past the eBooster whenever the combustion engine is operating in a state in which the eBooster is not providing any extra power in order to keep the pressure losses in the air system as low as possible. With respect to the function of the eBooster unit, it is therefore ultimately important to tune the volume of the overall intake system and to make it as small as possible, thus supplying a certain pressure ratio as quickly as possible.

4. The eBooster

4.1 Engineering

The eBooster unit is a compact machine consisting mainly of a flow compressor, a high-performance electric motor, a housing with bearings and possibly integrated power electronics. Engineering possibilities arise from the comparatively low thermomechanical load of the eBooster unit implemented in this prototype. **Fehler! Verweisquelle konnte nicht gefunden werden.** shows a cross-sectional diagram of the first prototype.

The prototype has a water jacket for cooling purposes in order to allow temperature tests on a test bench. Analytical examinations have confirmed that the unit does not need water cooling when positioned accordingly and operated in a tuned operating mode. eBoosters in the next generation will also be made available in an air-cooled version for purely transient operations.

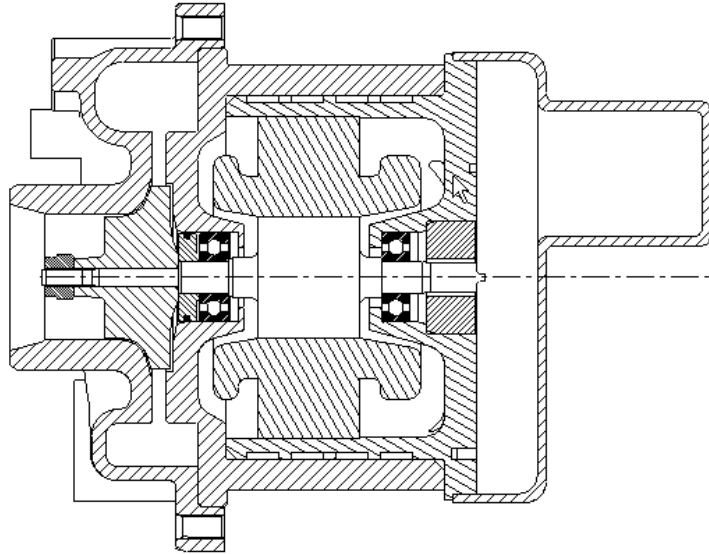

Figure 1 : Cross-sectional drawing of the eBooster unit

Due to conditions in the system, the maximum operating speed of the eBooster unit is below 100,000 rpm. For this reason and due to the comparatively low thermomechanical load, the bearing of the eBooster shaft is equipped with ball bearings that are lubricated for their entire service life. Since ball bearings have a fundamentally different damping capability than the oil-lubricated friction bearings usually used in turbocharger designs, the design of the shaft was accompanied by detailed numerical analyses. The rotor was modeled using mass, spring and beam elements and the resonating shapes were determined. An important boundary condition for the realistic modeling of the conditions in the simulation is knowledge of the axial and radial bearing stiffnesses as well as consideration of the stiffening effect of the compressor impeller combination on the shaft of the eBooster.

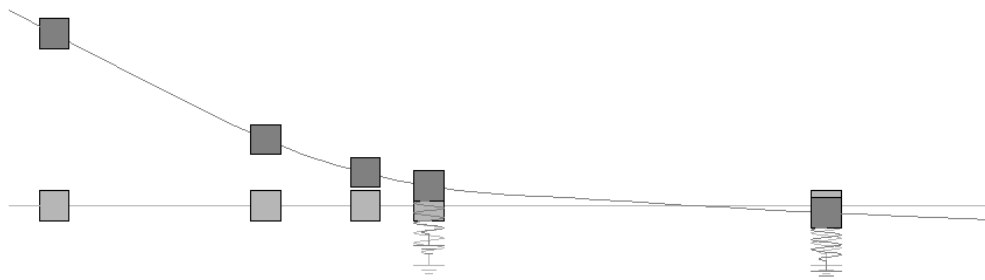

Figure 2 : Normal and deformed structure at the first critical bending resonant frequency

Fehler! Verweisquelle konnte nicht gefunden werden. shows a graph of the eBooster shaft when operating at the first critical bending resonant frequency. This frequency is above 2000 Hz and therefore clearly outside of the maximum operating speed. The second critical bending speed is at 3250 Hz. The shaft of the eBooster is a compact design and is designed so that no critical bending resonant frequencies lie anywhere in the entire operating range of the eBooster. The overall design of the shaft represents a compromise between the demands resulting from the design the electrical machine and the demand for a low mass moment of inertia while taking the results of the shaft dynamics calculations into account.

The bearing used was developed in cooperation with a ball bearing manufacturer,

accompanied by numerical calculations. Depending on the mounting position of the eBooster, the bearings are loaded radially by the weight of the shaft and possibly by a residual imbalance. In contrast to standard turbochargers the thrust generated by the operation of the compressor is not partially compensated. The load is distributed axially on the bearing. Due to the operating principle of the eBooster, all forces except for the inherent weight of the shaft appear transiently. The shaft of the eBooster is accelerated in the shortest possible time from a complete stop or from a base idling speed to its final speed. The balls and bearing retainer are subject during this time to heavy strain. Classic methods for calculating bearing design durability can only provide partially qualified results for the cumulative load demonstrated in this case during high rpm speeds.

The bearing of the eBooster shaft is produced using hybrid bearings. These bearings are characterized by metallic rolling rings and ceramic bearing balls. Hybrid bearings expand the limits of applicability of metallic ball bearings, especially with respect to speed. Due to the lower density of the ceramic bearing ball material, smaller dynamic forces are applied to the set of bearing balls at the same boundary conditions. The bearings are filled with a suitable grease that lubricates the bearing for the entire service life of the machine. The functionality and durability of this grease must be guaranteed for a comparatively wide temperature range and is therefore subject at each start-up to a substantial shearing load.

Important for the functionality of the bearing is that the sizes of the bearing seats on the housing and shaft are matched. The bearings are preloaded axially by a defined load and are therefore always subject to a minimum load. On the one hand, this guarantees that thermal differential expansion can be withstood within certain limits, and on the other hand that the bearings never have any axial play in any operating state, which would in turn result in significant degradation of the service life.

4.2 Voltage levels

In addition to the examinations related to the technical advantages of the eBooster system in the vehicle in terms of thermodynamics and combustion, the interaction and the integration of the system in an automobile electrical system must also be examined. If the energy consumption is relatively low during a boosting phase, that is at only a few kJ, then the short-term energy extraction during kW range consumption periods can be considered a challenge for a modern vehicle electrical system. The load placed on the vehicle electrical system during a boost phase is about the same as when starting. Since the vehicle electrical system of today is designed so that the one-time start-up procedure (especially when performed at low temperatures and when followed by a short driving period) almost reaches the performance capability limits of an electrical system battery, then frequent loading of the vehicle electrical system on this order places the usefulness of such a system in question.

A promising idea arising in previous years was the idea of introducing a higher-capacity vehicle electrical system with a higher voltage called the 36V (or, during the recharging phase, the 42V) vehicle electrical system. During this time it was decided to design the eBoosters of the first and second generation for an operating voltage of 42V. In the meantime, however, automobile manufacturers have shied away from introducing the 42V electrical system for reasons of component availability, compatibility with the current vehicle electrical system and the substantial cost as well. Development work is therefore being concentrated again on higher-performance 12V electrical systems.

In this case there are several possibilities that are primarily concerned with providing high performance quickly with the help of additional intermediate electrical storage with higher power densities than commercial lead acid batteries. In such systems the use of the eBooster also makes sense for existing vehicle platforms. Current ideas tend towards the

integration of the system in the existing 12V electrical system without negatively affecting the performance or, in particular, the stability of the voltage.

4.3 Electric motor

The design and engineering of a suitable drive motor is also based in this application on the demands resulting from the torque requirement of the compressor impeller as well as on the extremely short startup time, which results in an additional, considerable torque requirement to accelerate the rotating masses. Emphasis is also placed on the demand for a robust as well as economical design.

An electric motor with mechanical commutation, which is generally used as an economical alternative in each vehicle for most drive applications, cannot be used in this case due to the high speeds and the associated dwindling reliability of the commutator/brush system. For this reason, only electronically commuted motors can be used, i.e. permanent magnet-excited synchronous machines (SYM), reluctance machines (switched reluctance machine, SRM) or asynchronous machines (ASM) (Figure 6) with the appropriate electronics.

The most attractive solution without any doubt initially appears to be the SYM due to its loss-free provision of the excited magnetic field, the high efficiency generally resulting from this fact and its insensitivity to the design size of the air gap. One problem with this solution, though, is the limited tensile strength of the permanent magnet material, which can only be compensated for through additional design measures such as straps, for example. Furthermore, the constant excitement creates interference, even when there is no load and the machine is turning and the hysteresis and eddy current losses created in the iron produce a braking moment of inertia. The SYM requires a rotor position detector.

The SRM is interesting from a manufacturing point of view. Its stator coils are easy to manufacture and can be pushed through the hole in the stator and stuck on the teeth of the stator. The rotor has an especially low mass moment of inertia due to its characteristic tooth contour. The coil-end face of the rotor is covered so that the rotor itself does not generate too many losses due to friction with the air. This machine also requires a device to detect the position of the rotor, and this device must also be able to precisely detect the rotor angle.

The ASM design with the cast aluminum rotor cage is considered to be especially robust, is well-known in the field of manufacturing technology and can be operated without a special rotor position detector. It has one disadvantage in that heat that needs to be drawn off is generated in the rotor due to the currents in the aluminum cage. In terms of the complexity of the coils, the SYM coils are as complex as a coil for three-phase current with three windings.

The samples of the first and second generation were equipped with an ASM, and the high speeds were reached using it in the prescribed time without any problem. A simple speed sensor allowed us to check the current speed on the test bench. The machine accelerates according to a predefined speed ramp given by the control electronics software that depends on the compressor impeller used. Regulation of the slip ensures that no undefined states arise when the load changes. The thermal stresses that arise only permit periodic duty for such a small motor. With additional temperature sensors for monitoring purposes, more robust operation was made possible on the internal combustion engine test bench as well as in the vehicle.

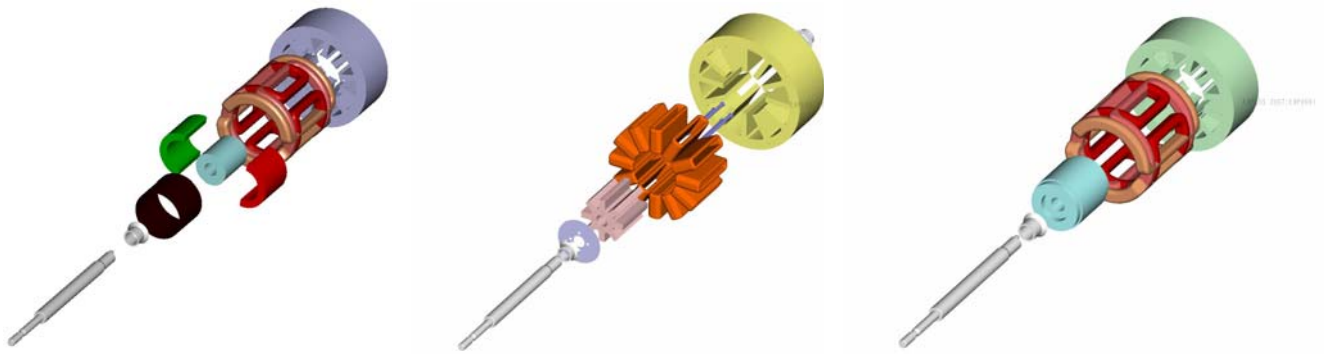

Figure 8 : Permanent magnet-excited synchronous machine (SYM), reluctance machine (switched reluctance machine, SRM), asynchronous machine (ASM).

4.4 Power electronics

After basic proof of the functionality was attained with the first eBooster generation, emphasis was placed in the second generation on a robust electronic control system designed to be as flexible as possible. With this control system it was possible on the internal combustion engine test bench as well as in the vehicle to determine the requirements profile necessary to create detailed technical specifications.

The electronic components are subject to high loads when used in internal combustion engine applications. This applies to the temperature range as well as to the high currents and the electromagnetic compatibility to be attained. In addition, there are the strains resulting from the frequent mounting and removal of the unit in the course of the test phases. While it should be considered a goal to integrate the power electronics in the eBooster housing, it is mostly an advantage when the electronics are protected from accidental, improper operation or incorrect connections during the first system tests on the test bench. For this reason the samples were equipped with a polarity reversal protection device in spite of the high current levels. In this case there is potential for improvement with respect to the achievable efficiency. The temperature of the power electronics is monitored separately from the temperature of the engine and is installed in a housing available as a mass-produced component. "Robust" operation is therefore possible.

There are three main control signals used to control the eBooster. Two of them control the startup and final speed, respectively, and the third controls the acceleration time. The electronics output a speed signal for control purposes, but also to permit pressure control, and have a second operating mode that permits continuous adjustment of the compressor impeller speed.

The circuits of the power transistors allow a regulated current to be applied to the coils of the three-phase electric machine in both directions. There is also an operating mode that permits pulse width modulated power curves for the continuous adjustment of the speed and a square-shaped curve for fast control and low losses in the electronics. Since the size of the electric machine is about the same as that of a 30 W machine operating in the system at room temperature, continuous operation at higher performance levels is impossible due to the thermal load. That is why there is no power feedback, especially considering the fact that intervention in the energy balance has not been sufficiently examined in terms of the thermodynamics or the electric system.

5. Results

While emphasis was placed during the first development phase on the basic functionality of the eBooster unit [8], emphasis was placed during the second phase on demonstrating reliable prototypes to prove the effectiveness of the eBooster charging system on the combustion engine in test bench operations as well as in vehicle tests. The development status will be discussed in the following based on experimental and numerical results.

5.1 Numerical results

After the first numerical tests using suitable procedures were performed externally on the eBooster in close cooperation with a technology institute [13, 14], BorgWarner Turbo Systems used the interim period to garner expertise in numerical simulation relating to turbocharger design and provision of direct support to the development work [12]. The GT Power computer program, often used by customers due to its high performance and synergy effects with development departments, was used. The program can model transient processes in addition to the steady-state response, which is especially important for the eBooster charging system.

One requirement for the realistic modeling of the transient processes is the calibration of the calculated model based on the data obtained from the steady-state experiments conducted on the corresponding combustion engine and the input of additional parameters that determine the transient response (for example, the mass moment of inertia of the rotating blades).

Due to the increase in charging pressure achievable even at low engine speeds, it is possible to improve the dynamic driving response. The driving response improves noticeably due to the fact that the charging pressure is built up quickly and the resulting torque is higher. In the simulation the influence of other compressors on the start-up response of the eBooster and its effect on the combustion engine can be estimated quickly and easily. The mass moment of inertia of the rotor increases unproportionally as the rotor diameter increases. The design of the eBooster compressor impeller represents a compromise between a high pressure ratio at the lowest possible speed (which means a large diameter wheel) and the lowest possible mass moment of inertia (which demands a small diameter wheel) in order to reach this speed in the shortest time possible.

Figure 7 shows the build-up of the charging pressure with and without the eBooster for a load change at 2000 rpm. The torque of the engine increases according to the charging pressure. The transient calculation with the integrated version of the eBooster shows a dramatically improved dynamic response. The results of the simulation closely mirror the measurements taken on the motor test bench. In terms of the location of the charging system, considerable advantages were detected in the case examined in the simulation when the eBooster was placed after the turbocharger compressor.

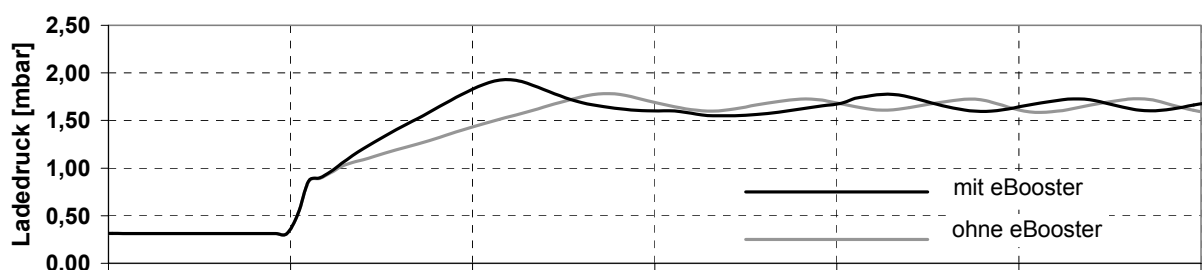



Figure 7: Simulation of the build-up of the charging pressure and torque for a load surge at 2000 rpm

5.2 Experimental results

A testing facility was assembled at BorgWarner Turbo Systems to experimentally test the eBooster. The test facility is equipped with special measuring technology to test the transient response of the eBooster unit (**Fehler! Verweisquelle konnte nicht gefunden werden.**). The test facility is controlled by a computer, and the computer also monitors the test bench and acquires the measurement data.



Bild 3 : eBooster test facility

In the test facility the eBooster is supplied with power from a constant voltage source. The eBooster is connected to a cooling unit that supplies the unit with water at a constant temperature to produce comparable conditions for each test. An air-cooled version of the eBooster can also be designed for the corresponding application profile and ambient conditions present at the mounting position of the eBooster. Two of the samples available were successfully operated, i.e. without any failures, in vehicle applications for several thousand kilometers without a connection to the cooling water system.

Only one electric motor model with the corresponding power electronics was developed initially at ebm due to the high costs of development. The project-specific modifications to the eBooster unit as well as the design of the turbocharger were made using matched eBooster compressors as well as by replacing an electronic chip in the power electronics.

In addition to several eBooster-specific compressors, models 1870 EAA and 2075 ECD have been used to date. Due to the low mass moment of inertia, acceleration times are about 0.2 s faster and higher speeds are reached with the 1870 EAA compressor for a lower power requirement. The pressure and mass flow remain below those of the 2075 ECD in accordance with the compressor maps.

The results shown here were obtained with the 2075 ECD compressor model. Figure 8 shows a graph of the speed of the eBooster and of the pressure ratio when allowed to exhaust freely and when there is a diaphragm in the pressure line, i.e. for various back-pressures. The graph is set up so that the eBooster is activated at the times $t = 1$ s and $t = 2$ s. Regardless of the back-pressure, the unit reaches a speed of about 86,000 rpm in 0.7 s. When accelerating to this speed and when there is no diaphragm in the pressure line, a pressure ratio of about 1.2 is reached when in the stationary steady-state, i.e. when the steady-state power requirement is the greatest. The maximum pressure ratio reached at this speed is about 1.35, which is in accordance with the characteristics of the 2075 ECD compressor.

Figure 9 shows a graph of the current strength when starting up the eBooster. Immediately after the machine is activated, the current consumed by the prototype available increases dramatically and increases further during the acceleration phase. The power required for compression increases during the startup phase according to the increasing mass flow rate and pressure ratio. More and more output is necessary to accelerate the rotating parts to overcome a specific difference in speed in the same amount of time as the speed increases. As soon as the final speed is reached, the acceleration process is stopped and the steady-state current consumed corresponds to the efficiency. When Figure 9 is compared to the results shown in Figure 8, it is clear that after activating power there is initially a lag time period followed by an acceleration phase delayed by about 0.1 s. The reason for this can be found in the way these power electronics operate and will be eliminated in the next development step.

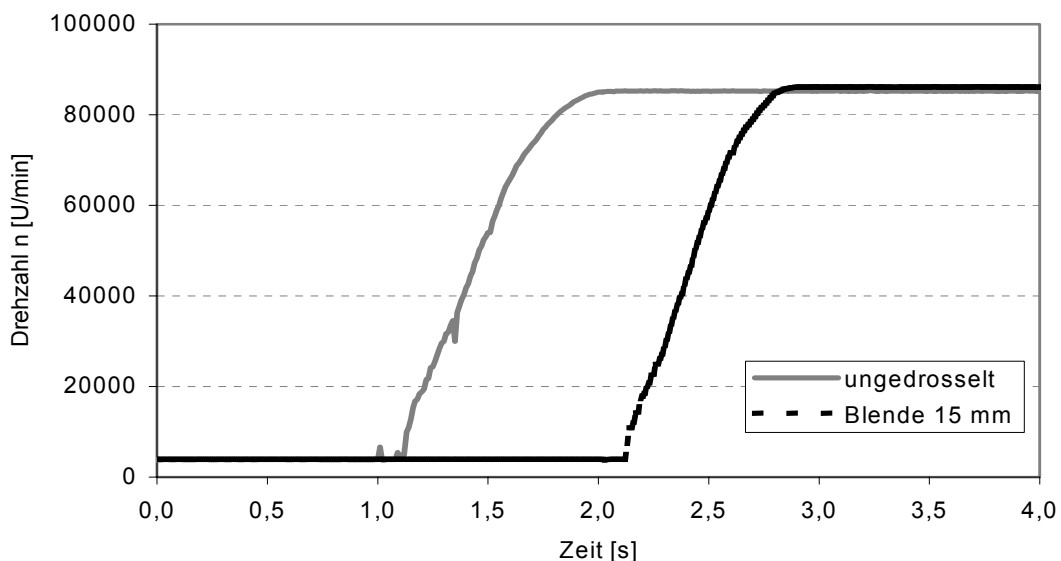

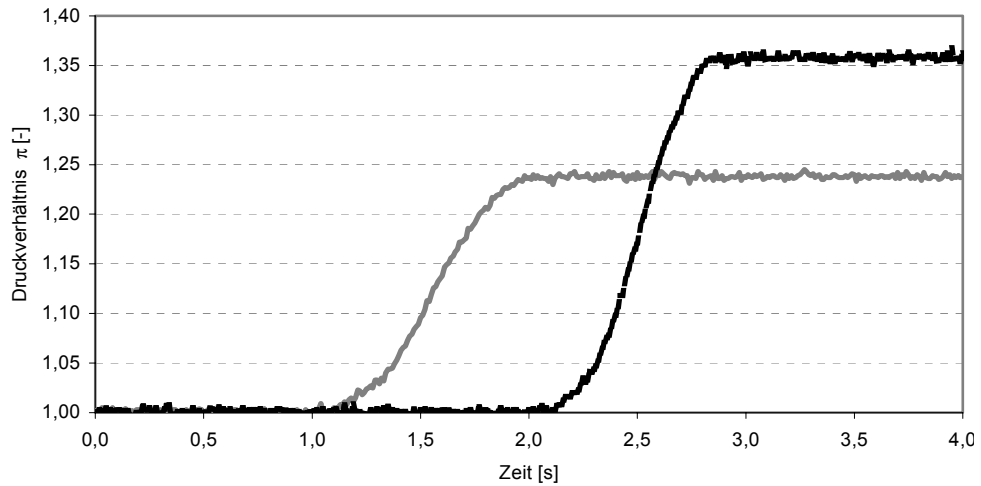

Figure 8: Speed and total pressure ratio

In terms of the strength of the current consumed when using the eBooster in the end phase of the acceleration it becomes clear that a reduction in the maximum power consumption is necessary, especially when the amount of power available even in modern 12V vehicle electrical systems is considered. Since the power needed when starting up for compression is determined by the thermodynamics and by the efficiency of the compressor, the reduction of the mass moment of inertia of the rotating blades becomes extremely important as well as improvements in the efficiency. The first step taken in this regard at BorgWarner Turbo Systems was to develop compressor impellers made of a suitable plastic characterized by a density about half that of aluminum while still providing sufficient strength properties. The acceleration time was reduced by about 0.1 s for the same power input through this measure.

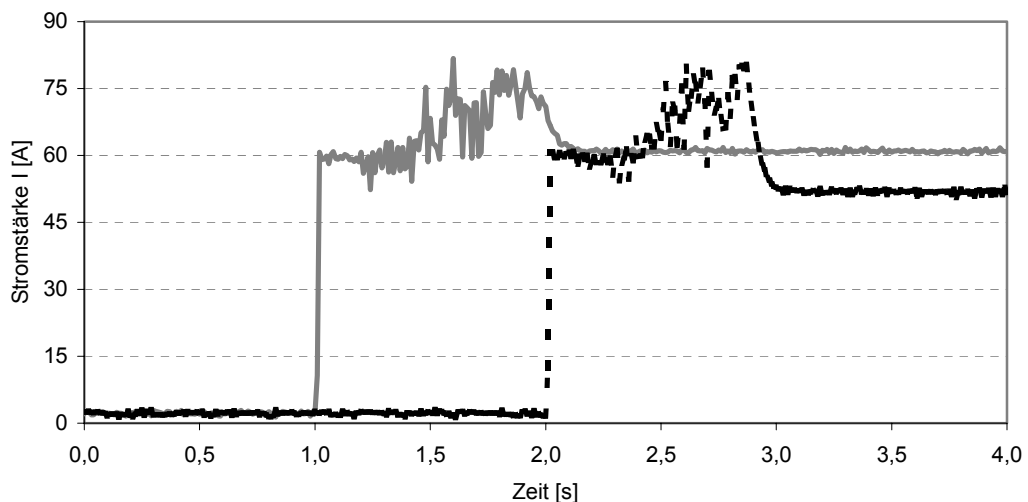

Figure 9: Current strength (see Figure 8 for a legend)

6. Outlook and additional procedures

The goal of this prototype was to prove the effectiveness of the eBooster in conjunction with the turbocharger on the combustion engine in test bench operations and vehicle tests as well as to prove its reliability and robustness. This effectiveness was demonstrated in several projects conducted in close cooperation with the customer for gasoline engines and diesel engines.

During the discussion of the experimental results an important goal of any further work to be done, namely the reduction of the mass moment of inertia, was addressed in conjunction with a reduction in the required acceleration performance or an additional improvement in the dynamics of the unit. Redesigned compressor impellers made of a heavy duty plastic are already making an important contribution. Figure 10 gives you an idea of a possible new eBooster design. In addition to the measures described above, omnidirectional finning was used in this case to cool the unit with air.

Further potential for improvement can be found in the rotor of the electric motor and the optimization of the overall design. A reduction of the diameter of the rotor also has an effect on the torque response of the engine. It may be sensible in this context to change to a different type of electric motor. Initial tests show that the reluctance machine in particular can yield improvements in terms of the mass moment of inertia as well as in the efficiency for this type of application.

The advantages of the cooperation between BorgWarner Turbo Systems and the ebm Werke and Co. KG become clear in this context. The development of this electric system, which was able to demonstrate its advantages over other approaches in various customer projects, not only requires experience in the charging of combustion engines and the mass production of and competency with turbochargers, but also requires similar experience with electrical and electronic components.

The effectiveness of the unit was proven for the combustion engine in various projects, but the primary factor in deciding upon the use of electric charging in production vehicles is mainly the vehicle electrical system architecture. From the point of view of the authors, a 42V vehicle electrical system with the appropriate capacity, after the initial euphoria, will very probably not be used in the coming years, at least not in those vehicles in which the use of the eBooster comes into question.

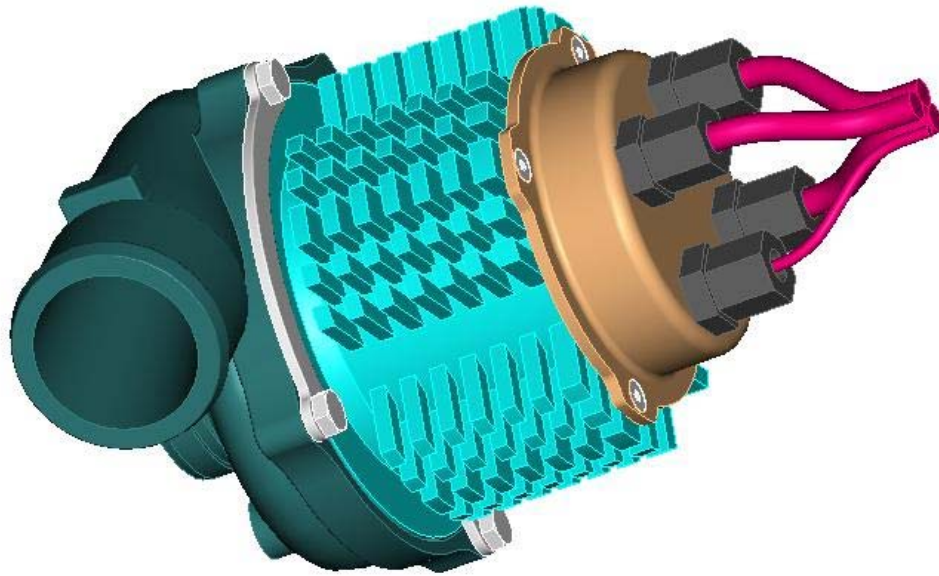

Figure 10: Design study to refine the eBooster

This means that efforts are to be concentrated on a 12V solution. It is well known that many approaches to improve the 12V electrical system will be taken due to the wide variety of power consuming devices, whether for purposes of comfort or higher performance. While in a higher performance 42V vehicle electrical system the use of electrical consumers like the eBooster would probably be possible without any special extra measures, there are limits to the output of an innovative, higher performance 12V electrical system. Initial analyses in this direction show that the use of an eBooster in a modified 12V vehicle electrical system is technically possible. From the information presented, it becomes clear that there is another major course of development possible to refine the system: an innovative charging system that contains the turbocharging components and that can also be integrated into a higher performance 12V vehicle electrical system.

Bibliography

- [1] Schult-Bornemann, K.-H.
Mineralölwirtschaft-Der internationale Rohölmarkt
BWK-Das Energie-Fachmagazin, Springer VDI Verlag, Ausgabe 4 / 2001
- [2] Hoecker, P.; Pflüger, F.; Jaisle, J. W.; Münz, S.
Moderne Aufladekonzepte für PKW Dieselmotoren
7. Aufladetechnische Konferenz, Dresden, 28. – 29. September 2000
- [3] Oberholz, G.; Pflüger, F.
Downsizing- Aufladekonzepte für Ottomotoren
Konferenz „Downsizingkonzepte für Otto- und Dieselfahrzeugmotoren“, München
26.- 27. Juni. 2000
- [4] Pflüger, F.
Regulated two-stage turbocharging - KKK's new charging system for commercial diesel engines
6th International Conference on Turbocharging and Air Management Systems, London
ImechE Conference Transactions, 1998
- [5] Krieger K.
„Es ist viel besser, Emissionen zu vermeiden, als sie mit Abgasnachbehandlung zu senken“
Interview mit K. Krieger, MTZ 4 / 2002, 63. Jahrgang
- [6] Shahed, S.M.; Allen, W. ; Lin, E.; Barrios, K.; Birch, K.
Elektrisch unterstützte Turboladersysteme für konventionelle, Hybrid- und Brennstoffzellenantriebe
Wiener Motorensymposium, Wien, 2000
- [7] Kreuter, P.; Bey, R.; Wensing, M.
Impulslander für Otto- und Dieselmotoren
Fortschritt-Berichte VDI, Reihe 12, Nr. 455
- [8] Hoecker, P.; Jaisle, J.W.; Münz, S.
Der eBooster – Schlüsselkomponente eines neuen Aufladesystems von BorgWarner
Turbo Systems für Personenkraftwagen
Fortschritt-Berichte VDI, Reihe 12, Nr. 455
- [9] Zellbeck, H.; Friedrich, J.; Berger, C.
Die elektrisch unterstützte Abgasturboaufladung als neues Aufladekonzept
MTZ Motortechnische Zeitschrift 60 (1999)
- [10] Huber, G.
Elektrisch unterstützte ATL-Aufladung (euATL), Schaffung eines neuen Freiheitsgrades bei der motorischen Verbrennung
6. Aufladetechnische Konferenz, Dresden, 1. – 2. Oktober 1997
- [11] Warnecke, W.
„In der Übergangszeit auf fossile Brennstoffe konzentrieren“
Interview mit W. Warnecke, MTZ 6 / 2002, 63. Jahrgang

- [12] Gabriel, H.; Schmitt, F.; Weber, M.; Lingenauber, R.; Schmalzl, H.P.
Neue Erkenntnisse bei der variablen Turbinen- und Verdichtergeometrie für die Anwendung in Turboladern für Pkw-Motoren
Fortschritt-Berichte VDI, Reihe 12, Nr. 490

- [13] Zellbeck, H.; Friedrich, J.
Simulation des Beschleunigungsverhaltens von PKW-Ottomotoren mit neuen Aufladeverfahren
Wiener Motorensymposium, Wien , 1999

- [14] Zellbeck, H.; Friedrich, J.
Optimierung des dynamischen Verhaltens aufgeladener Verbrennungsmotoren
7. Aufladetechnische Konferenz, Dresden, 28. – 29. September 2000

BorgWarner Turbo Systems
Worldwide Headquarters GmbH
Mannheimer Strasse 88
67292 Kirchheimbolanden / Germany
Phone: ++49 (0)6352 75 33 0
Fax: ++49 (0)6352 75 33 99

BorgWarner Turbo Systems GmbH
Mannheimer Strasse 85/87
67292 Kirchheimbolanden / Germany
Phone: ++49 (0)6352 403 0
Fax: ++49 (0)6352 403 1866

BorgWarner Ltd.
Euroway Industrial Estate
Bradford BD4 6SE
West Yorkshire / UK
Phone: ++44 1274 684 915
Fax: ++44 1274 689 671

BorgWarner Turbo Systems
PO Box 15075
Asheville, NC 28813/USA
Phone: 001 828 684 4000
Fax: 001 828 684 4114

BorgWarner Brasil Ltda.
Estrada da Rhodia Km 15
P.O. Box 6540
13084-970 Campinas-SP / Brasil
Phone: ++55 19 3787 5700
Fax: ++55 19 3787 5701

Hitachi Warner Turbo Systems Ltd.
3085-5 Higashi Ishikawa Saikouchi, Hitachinaka-shi
Ibaraki-ken
312-0052, Japan
Phone: +81 (0) 29-276-9388
Fax: +81 (0) 29-276-9397

www.turbos.bwauto.com

