

Dr.-Ing. Olaf Weber,
Dipl.-Ing. Volker Jörgl,
John Shutty, MS,
Philip Keller, PhD,

Future Breathing System Requirements for Clean Diesel Engines *(2005)*



 KnowledgeLibrary



BorgWarner
Turbo & Emissions Systems

Introduction

Exhaust Gas Recirculation (EGR) in combination with Turbocharging Technology is one of the decisive enablers for the Diesel engine to meet today's emission regulations. Increasing amounts of EGR are still being seen to lower Nox-emissions beyond known limits /1/. Both truck /2/ and passenger car environments are effected. Providing the required amount of EGR in combination with reasonable boost pressure can be therefore seen as one of the toughest challenges in lowering NOx emissions by engine internal technologies.

In the future, especially beyond 2010 additional measures might be taken into account /1/, but, as illustrated in figure 1, EGR will be fed to the engine as an inexpensive fluid for emission control, before additional exhaust aftertreatment infrastructures are introduced to the vehicle. In the end, the cost/benefit ratio of SCR for example, or NOx-traps and the performance of EGR-Boost systems will determine the future Diesel engine system configurations. The Diesel Particulate Filter (DPF) can be seen as an essential element herein.

Based on this basic question this lecture deals with different engine breathing systems taking into account the special needs of turbochargers and the interaction between EGR and boosting technology. The investigation has been made with a calibrated simulation model.

	Reduction potential		HC	CO ₂	Costs	Risks
	PM	NO _x				
EURO4 EGR — DOC — DOC	Baseline					
High-EGR combustion w/o DPF EGR — DOC — DOC	⊖	+	⊖	⊖	⊖	HC-Emissions Coking / contamination Combustion noise
High-EGR combustion with DPF EGR — DOC — DPF	++	++	⊖	⊖	⊖	Development effort BSFC penalty
UREA-SCR System EGR — DOC — DPF — SCR	++	+++	⊖	⊖	⊖	UREA consumption Costs / package
Lean Nox Trap System EGR — NSC — DPF	++	++	⊖	⊖	⊖	Aging / durability Regeneration strategy Costs

Fig. 1: Future Diesel Emission concepts, related to /3/

EGR-Boost Concepts

High pressure EGR (HP-EGR) take the exhaust before the turbine via an ECU controlled EGR-valve to the air intake, figure 2. For better breathing efficiency, EGR-coolers are being applied. These devices can deal with high temperature differences and particulate load in the exhaust. In addition, the application of gas/water charge air coolers may meet special package requirements. Niche applications today require even 2 stage cooling circuits to achieve the best thermodynamic results, see also figure 5. Deposit formation is an issue which cannot be totally prevented /4/. For that reason the untreated exhaust should not pass the charge air cooler which excludes its usage during part load conditions.

Classical HP-EGR reduces the turbine gas flow. The energy, driving the compressor, decreases while the necessary compressor pressure ratio increases to keep the engine running at the same load point. Closing the Variable Turbine Geometry (VTG) increases the exhaust back pressure and the energy provided to the turbocharger. For mild EGR concepts, used for EU 4, this kind of strategy is absolutely elegant and sufficient.

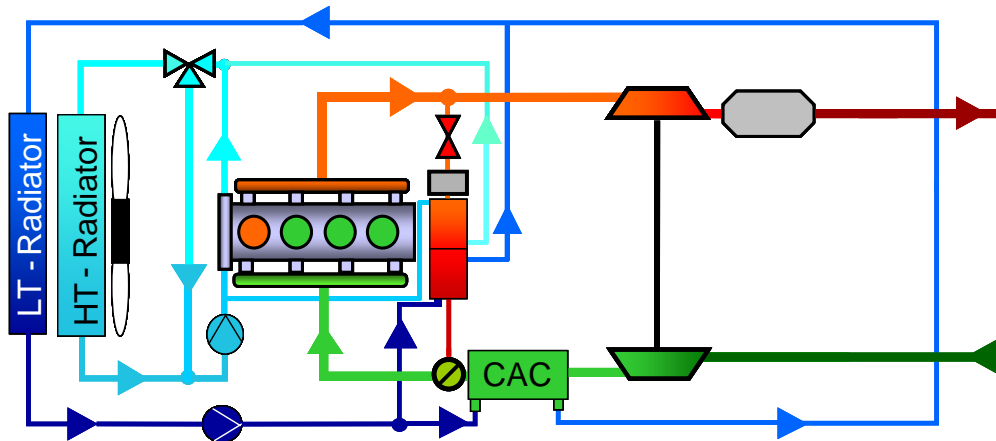

- low temperature coolant circuit
- engine temperature coolant circuit
- exhaust gas circuit
- Intake charge air circuit
- Exhaust after treatment

Fig. 2: High Pressure EGR-Boost System

However, as more EGR is demanded, the turbocharger cannot keep up and the operation point in the compressor map moves toward the surge line, figure 3. For advanced EGR-concepts like US 07 or EU 5 the turbocharger may not be able to deliver the necessary mixture of fresh air and exhaust to the combustion engine. There are different matching opportunities to improve this situation, but engine power output and fuel efficiency will suffer.

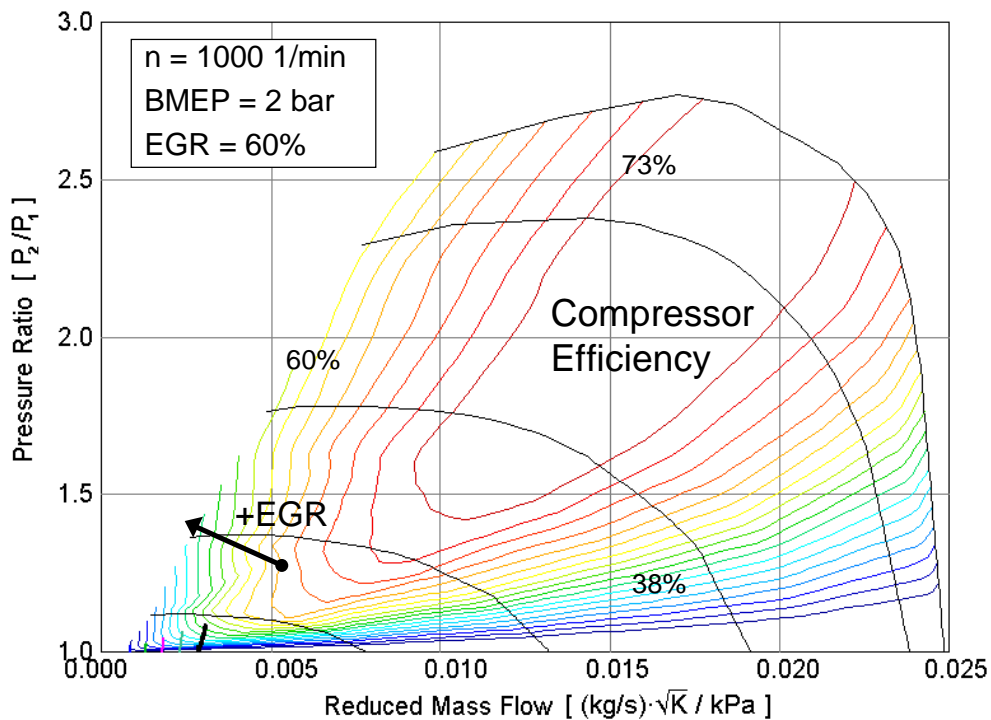

Fig. 3: Influence of High Pressure EGR in the Compressor Map

Low Pressure EGR Systems

Low pressure loop EGR is a well known technology that offers an alternative to meet the requirements mentioned above. The exhaust is taken after turbine and introduced in front of the compressor (figure 4). Before the market introduction of the Diesel particulate filter (DPF), the entire air intake system including the compressor would have been subject to deposit formation. This was one of the main reasons that limited the application of this kind of system.

The DPF can be therefore seen as the enabler of LP-EGR. The exhaust is cooler compared to HP-EGR and clean. It can be expected, even after recompression, that the thermal behaviour is superior to HP-EGR as the charge air cooler (CAC) is used in addition.

The LP-loop, like the HP-loop, is equipped with an EGR-valve. To increase the pressure difference between exhaust and air intake, especially to drive higher rates, an exhaust throttle is needed which will be closed to increase exhaust back pressure thereby increasing EGR.

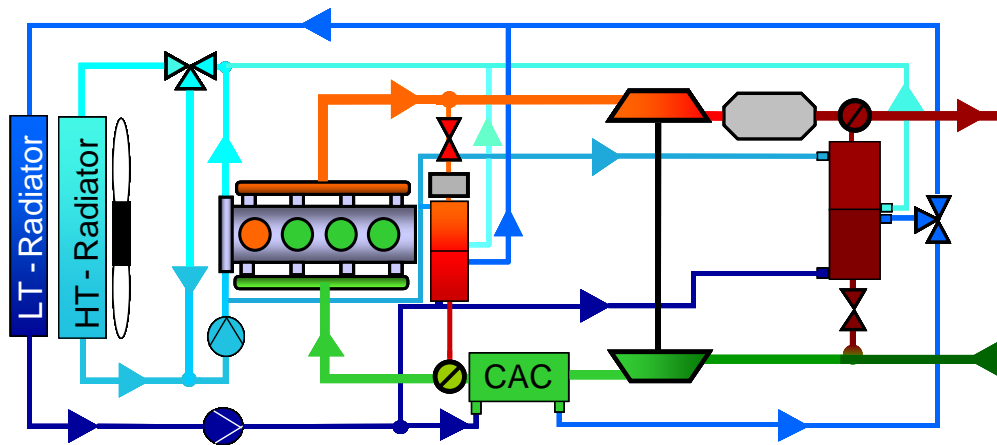

- low temperature coolant circuit
- engine temperature coolant circuit
- exhaust gas circuit
- Intake charge air circuit
- Exhaust after treatment

Fig. 4: Introduction of Low Pressure EGR-Loop

Thermodynamic Comparison of LP- and HP-EGR Systems

Figure 5 illustrates the introduction of the Low Pressure EGR-path. The engine has been operated at 2500 rpm at a load of 12 bar bmep and an EGR rate of 30%. The very left vertical line in the map represents the HP-mode. The other vertical lines represent increasing amounts of LP-Loop EGR. For each of the lines, VTG-position is varied from open (bottom) to closed (top). The very right, nearly vertical line expresses the same as before but under LP-mode. The lines in between are splits of HP- and LP-loop systems. The overall EGR-rate does not change. It can be clearly seen that the air mass flow is increased when replacing HP-EGR by LP-EGR. The turbine flow (not shown) is also influenced positively; better compressor efficiencies are obvious.

To complete the view, EGR-cooling helps to decrease the necessary pressure ratio and allows to open the VTG leading to better turbine efficiencies (not shown).

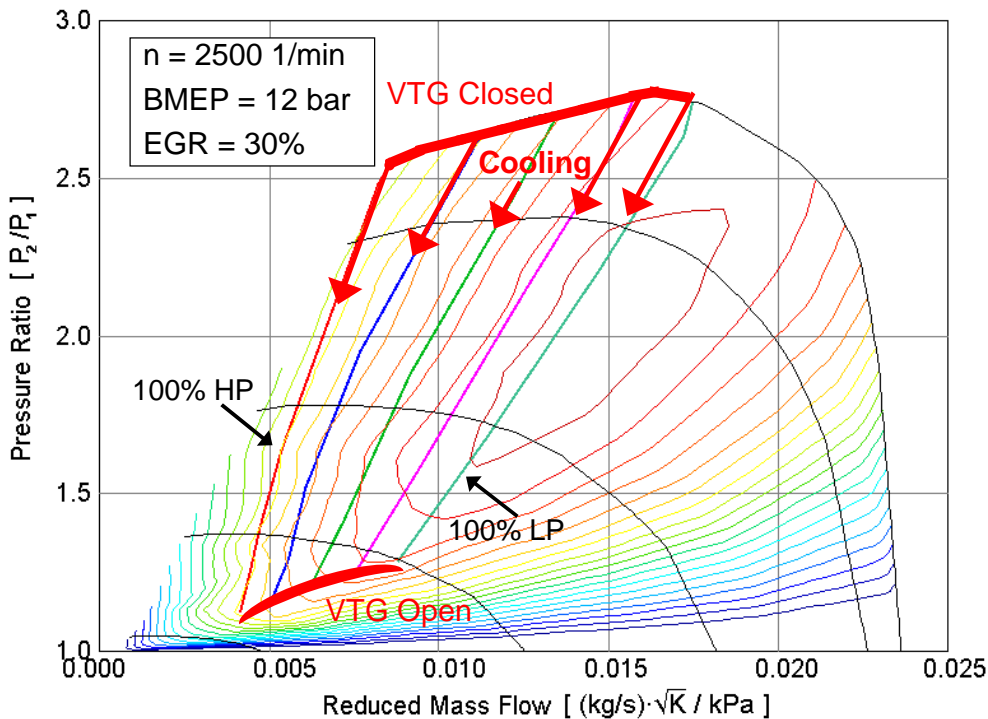

Fig. 5: Influence of VTG, EGR-Split and EGR-Cooling

The engine parameters Air/fuel ratio, PMEP and BSFC can be analysed in figures 6 through 8. Areas of Air/fuel ratio smaller than 1 have been excluded. The results are based on the relationship of turbine efficiency depending on VTG-position, pumping losses as part of boost pressure, the efficiency chain turbine-compressor and the necessity to add energy by fuel, represented by Lambda. Closed VTG and a high turbine flow (LP-EGR) increase the pumping losses in principal. The corresponding Lambda is high due to availability of excess air in the combustion chamber. In the end this leads to the best BSFC at the air fuel ratio of one for the widest open possible VTG position, represented by the right bottom corner of the operation maps within the compressor mappings. The best distance from the smoke limit will be reached with higher boost pressures created by closing VTG. This has to be paid by a slightly higher BSFC caused by higher pumping losses.

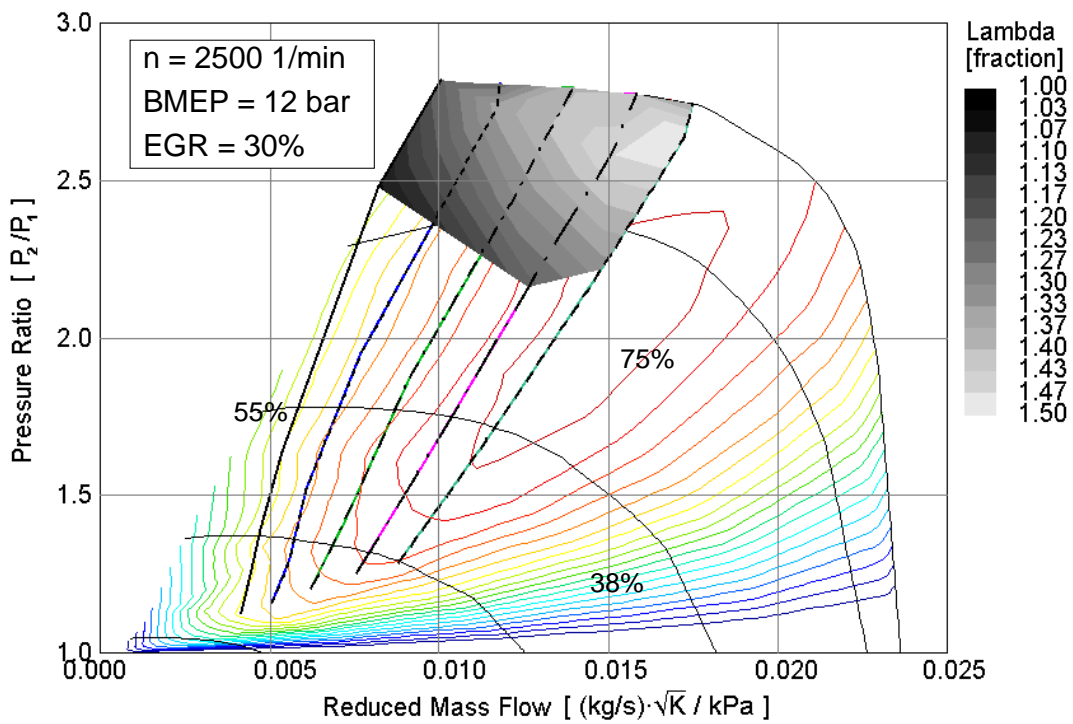

Fig. 6: Air Excess at 2500 rpm, 12 bar BMEP and 30% EGR

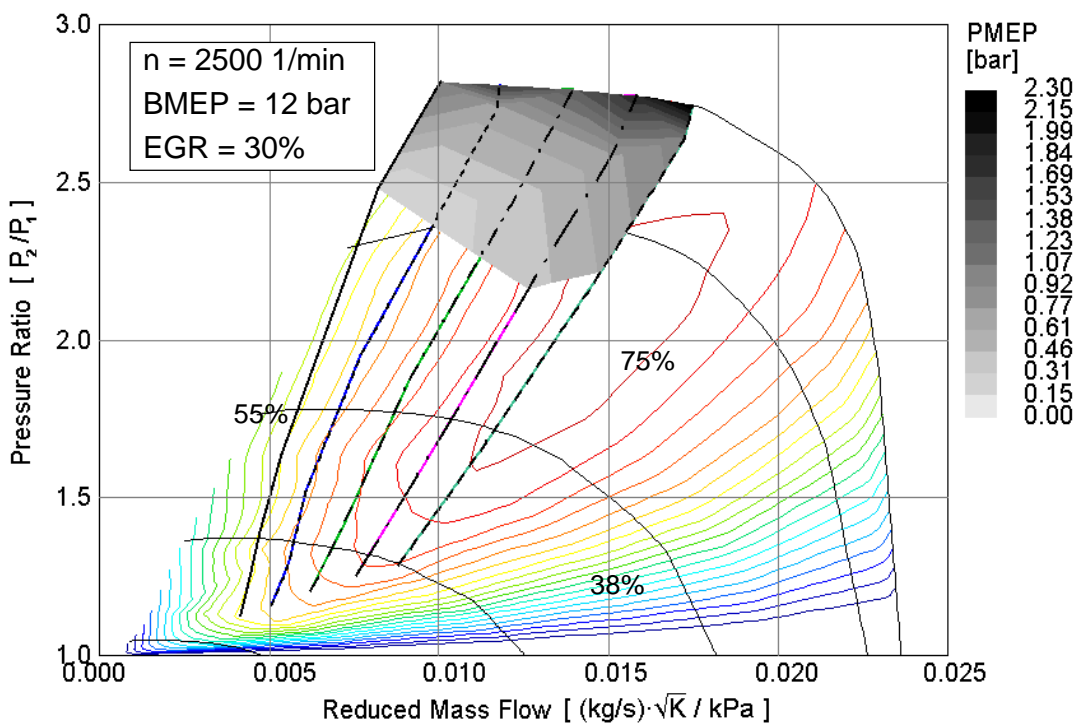

Fig. 7: Pumping Losses at 2500 rpm, 12 bar BMEP and 30% EGR

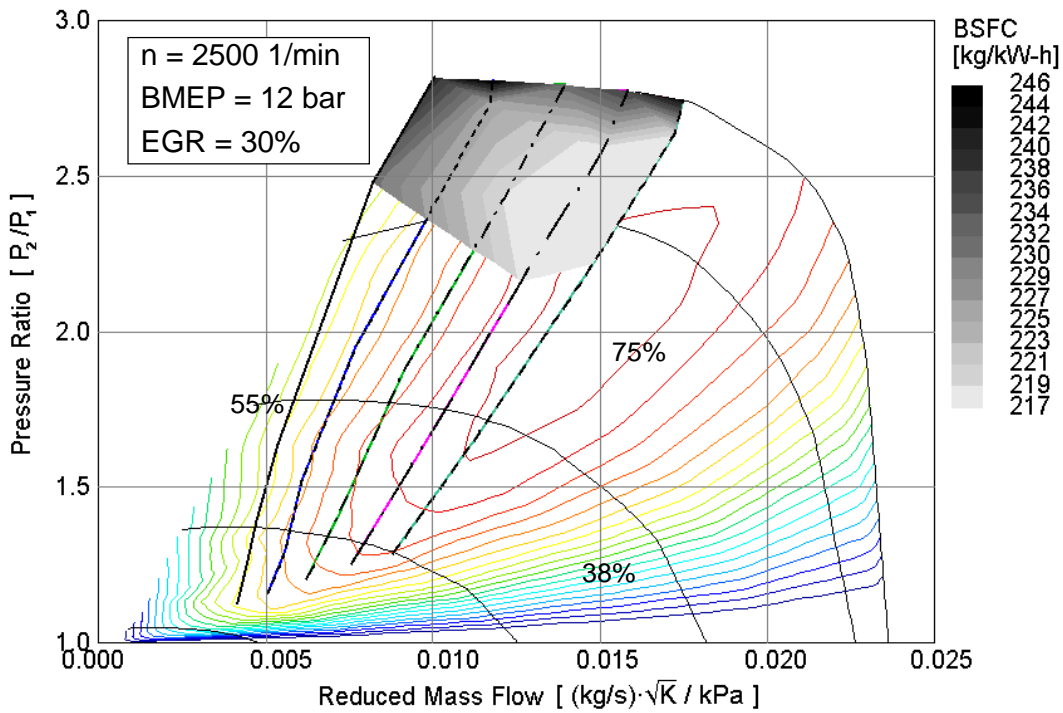

Fig. 8: Specific Fuel Consumption at 2500 rpm, 12 bar BMEP and 30% EGR

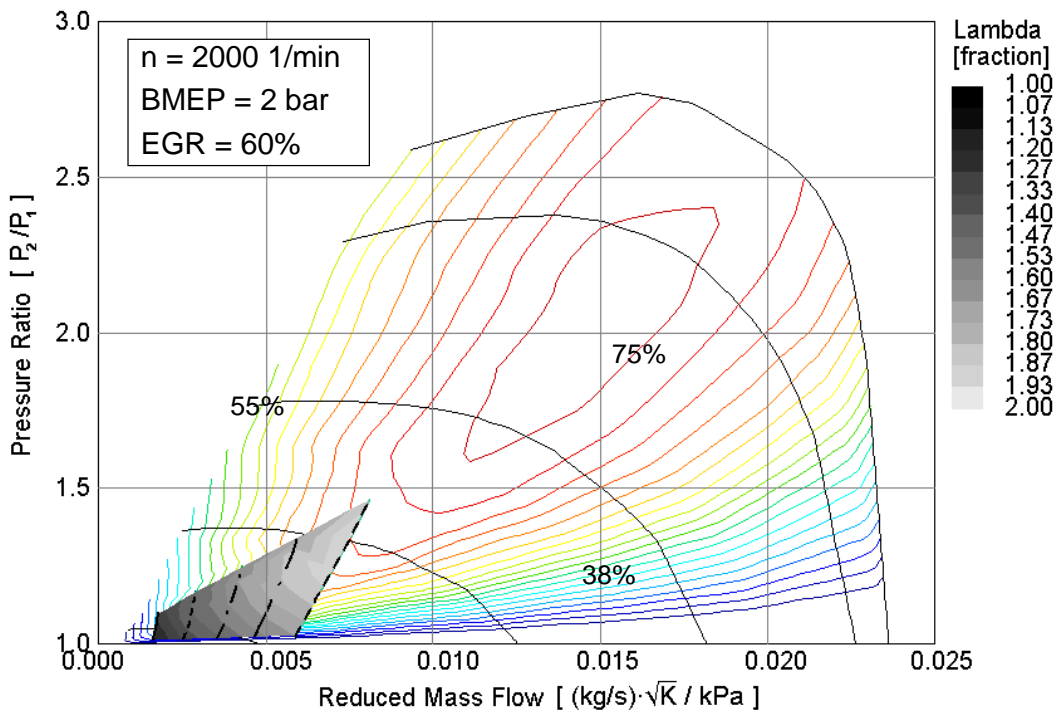

Fig. 9: Air Excess at 2000 rpm, 2 bar BMEP and 60% EGR

For low load conditions (2000 rpm and 2 bar BMEP) and a high EGR-rate of 60 % we find the same results in the figures 9 through 11. In addition, the benefit of a higher exhaust gas flow can be easier seen even where the turbocharger does not build up a significant boost pressure.

The significance between boost pressure and Lambda is higher as both turbine and compressor are just starting to work.

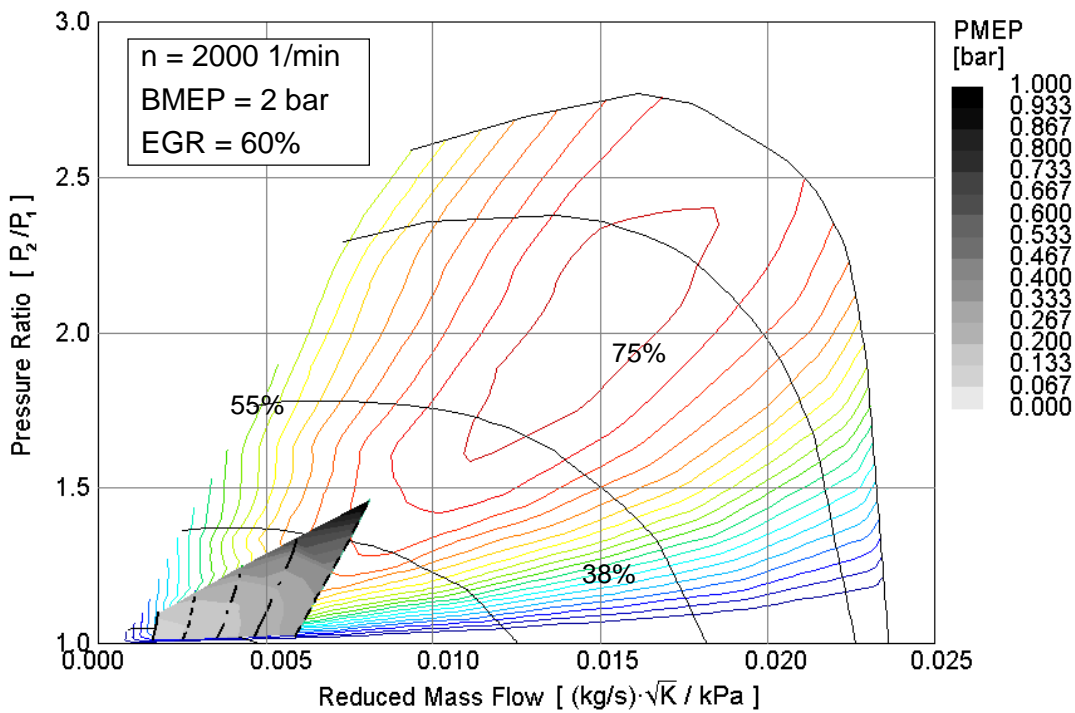

Fig. 10: Pumping Losses at 2000 rpm, 2 bar BMEP and 60% EGR

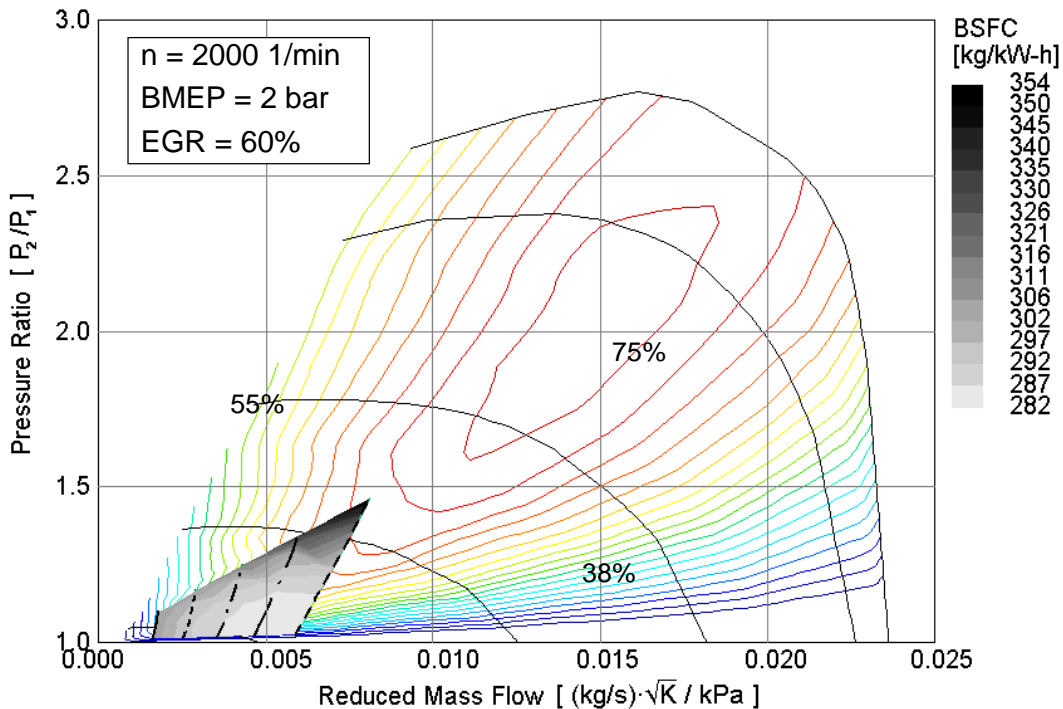

Fig. 11: Specific Fuel Consumption at 2000 RPM, 2 bar BMEP and 60% EGR

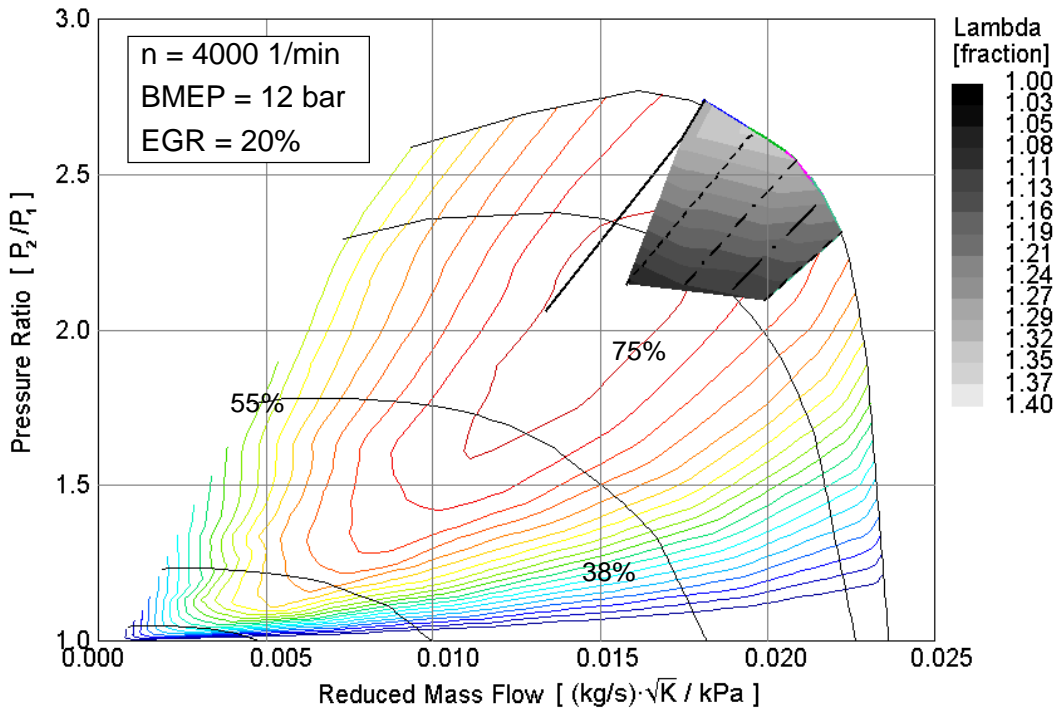

Fig. 12: Air Excess at 4000 rpm, 12 bar BMEP and 20% EGR

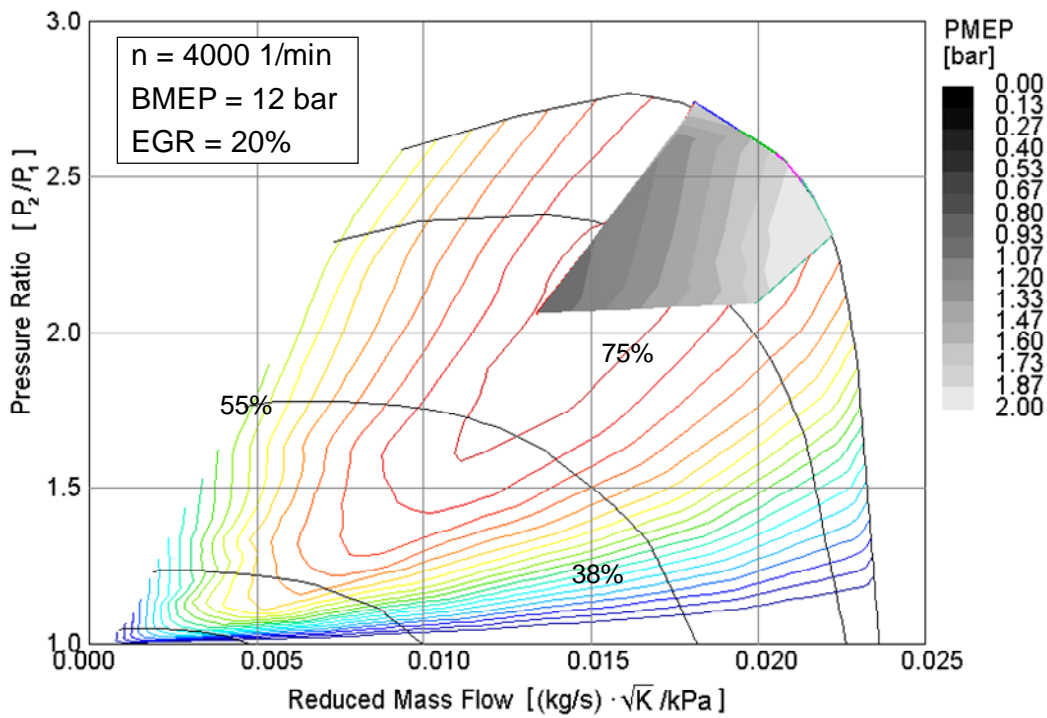

Fig. 13: Pumping Losses at 4000 rpm, 12 bar BMEP and 20% EGR

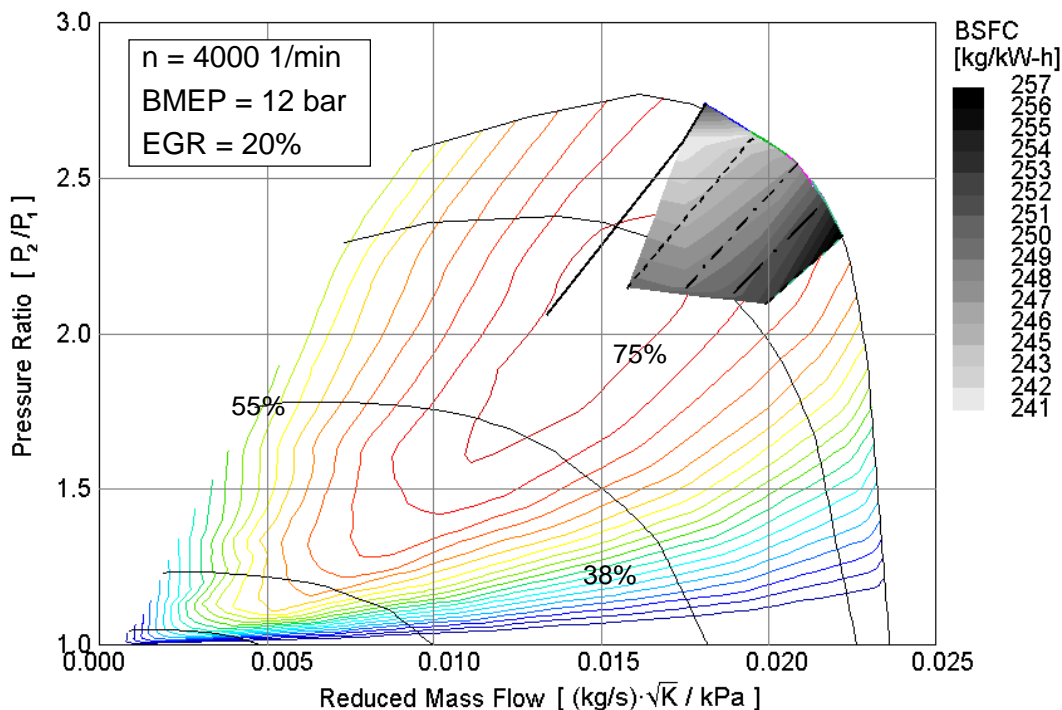

Fig. 14: Specific Fuel Consumption at 4000 rpm, 12 bar bmep and 20% EGR

The 2 operation points mentioned above are important for Pass Car Diesel engines due to the requirements in the emission test procedure. Truck applications have to deal with EGR at high speeds and loads. As the compressor efficiencies are decreasing by higher flows and turbine conditions aren't improved, either the best BSFC are reached on the HP-Loop mode area. In more detail, an EGR-split of 25% LP and 75% HP flow seems to be the best operation point. Figures 6 through 14 indicate an advantage of a split between HP and LP EGR. The split just optimises the exhaust gasflow as a best fit to the turbine characteristics. At low engine speeds/loads LP helps to increase the energy flow to the turbine. At high speeds HP EGR may help to avoid turbine efficiency deterioration by wide open VTG positions.

Engine Breathing Match

This understanding is even supported by different matchings applied to both LP and HP-EGR, figure 15. The x-axis shows the principal matching trend path like smaller compressor and/or smaller turbines. The clear objective is to help the system to pump air and EGR to the engine at low speeds/loads as indicated by the operation point.

The additional freedom in available energy in terms of air/fuel ratio and turbine power output gained by a new turbomatching is obvious but not significant. The peak power output is being deteriorated by that measure.

After introducing LP- EGR the additional energy potential is visible. Turbine power is increased by a factor of 3, air fuel ratio can be increased even at the basic turbomatching. The sensitivity of the LP-EGR-system in terms of turbomatching is another not surprising result.

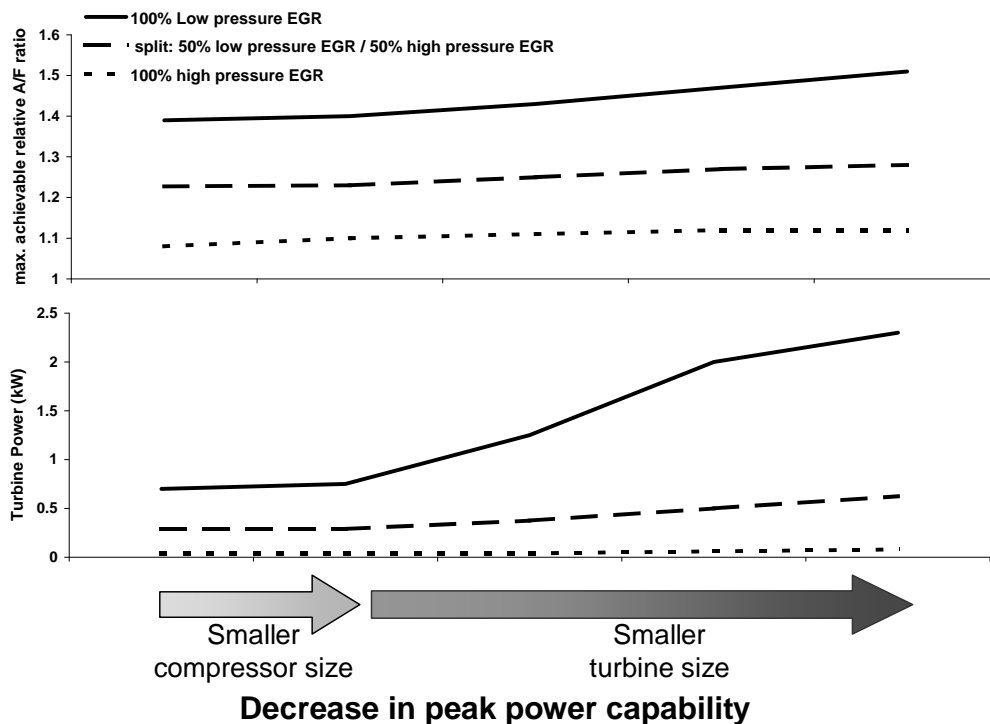

Fig. 15: EGR-Split Turbomatching, 1500 rpm, 2 bar bmep, 60% EGR

Transient Behaviour

LP-EGR- systems comprise a larger air intake volume than HP-systems. Especially applications with underfloor DPF will show a huge difference. Most of the discussions therefore focus on this possible disadvantage of LP EGR-systems when it comes to the transient behaviour of the Diesel engine. The additional pipes and volumes have to be emptied of the air/exhaust of the previous operation point which might require some time.

For that reason a comparison was run to find the relationships between HP- and LP-system-acceleration time, figure 16. The load step goes from 2 bar BMEP to 9 bar, including a reduction in EGR. This load step might represent part of the US06 test where especially small engines in heavy vehicles are facing the NOx-challenge.

The 3 charts present the BMEP, the necessary EGR-rate and the Lambda. The graphs show the differences between LP and HP, including different control strategies for HP.

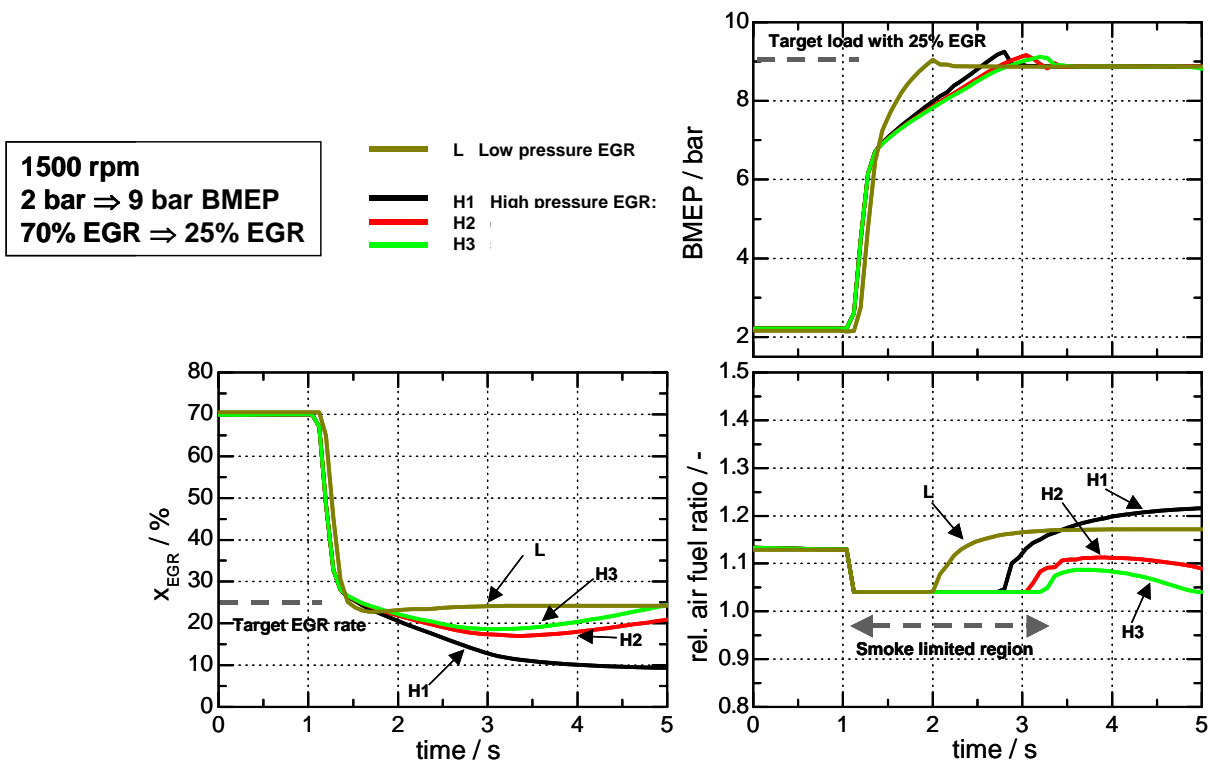

Fig. 16: Load Change at 1500 rpm

H1: strategy to achieve highest boost pressure, H2: compromise between H1 and H3 H3: strategy to achieve highest EGR

All strategies reach the soot limit of $\lambda=1.05$ soon. The low LP EGR-system reaches the required BMEP first and shows a nearly stable EGR-rate. Strategy H1, with the focus on fast increasing boost pressure, needs app. 1 sec to catch up and does not reach the necessary EGR-rate. The EGR trimmed Strategy H3 offers reasonable EGR response but is running near the smoke limit: the operating point represents the borderline performance of a HP-system even at 9 bar BMEP. The example emphasises the superior behaviour of a LP-system at mid loads and low speeds considering future need EGR-rates as mentioned before.

The Diesel engine used has a power output of less than 40 KW/l. The basic ability to handle EGR at low loads/speeds should be reasonable. Nevertheless LP shows significant advantages. Application with more than 50kw/l specific power output should therefore depend even more on the LP EGR-system properties.

The additional volume in the air intake of the LP EGR-system can be seen as a damping factor during transient during the filling process of a changed EGR-rate and boost pressure. The add on volume is created by the CAC, the compressor and necessary tubes, which have been assumed to fill 5 liters. Figure 17 extracts the BMEP curve of figure 16. The disadvantage caused by the LP-add on volume is negligible compared to the advantage in BMEP rise after 1.4 seconds. The higher initial turbocharger speed, enabled by the higher exhaust mass flow through the turbine, ensures a smaller “perceivable” load step for the turbocharger.

The simplified explanation for the enhanced dynamic response is a sort of replacement of EGR by fresh air. In that defined load step the compressor is just considering a rather small increase in turbocharger speed. This LP-advantage in transient response corresponds to the controllability.

In addition, the interaction with the VTG position is much less important than in a HP-system. The result can be seen in figure 16 where the targeted EGR rate is reached and kept with high precision.

When EGR rates will rise for future emissions regulation the demand of more responsive LP-systems will increase (figure 18). The higher the EGR-rate, the larger the difference in response time based on the dominant energy balance at the turbine.

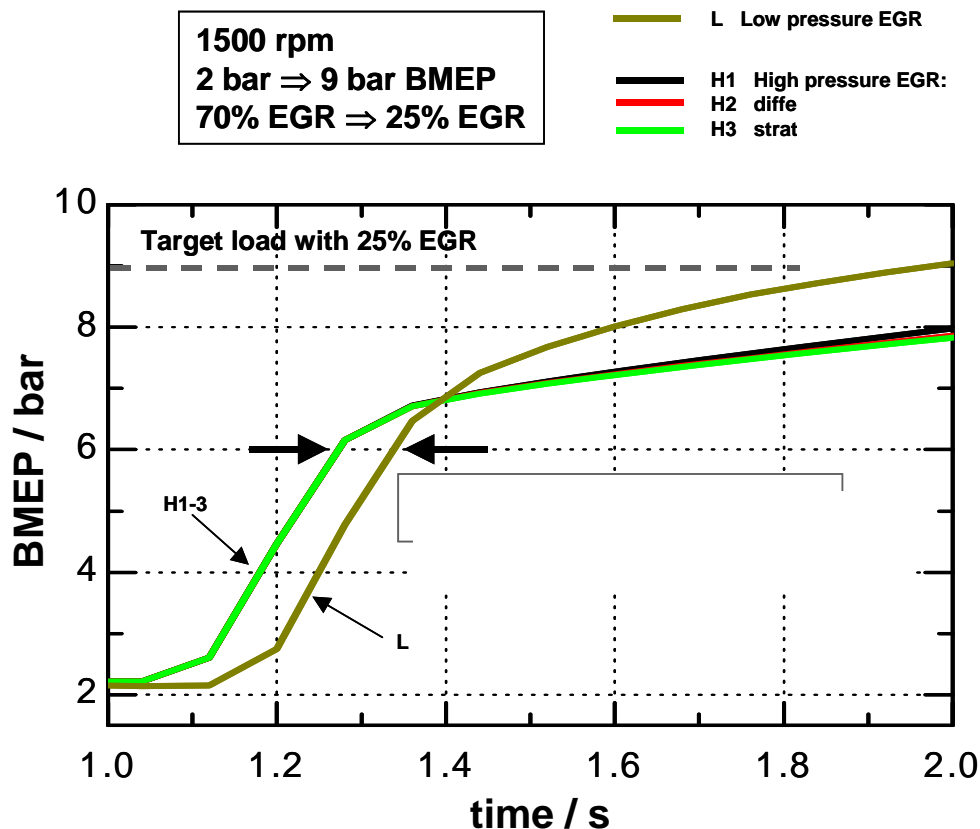

Fig. 17: Load Change at 1500 rpm, II

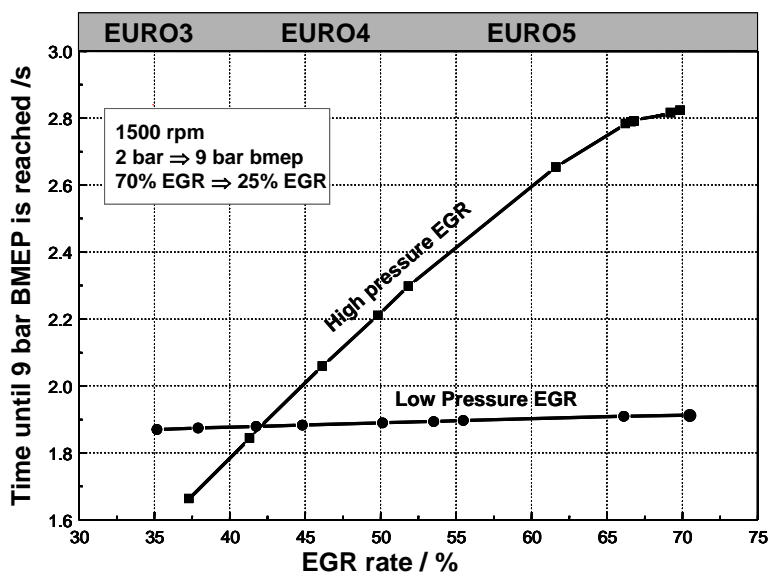

Fig. 18: Load Change for Different EGR-Rates and EGR-Split

Concept Comparison

















High pressure EGR	Low pressure EGR
<ul style="list-style-type: none">  Proven / developed system  Good BSFC at low speeds/loads possible (low pumping losses)  Intake throttling necessary for higher EGR-Rates  Dynamics suffer due to low turbine speeds  Low possible λ due to low intake air density and boost pressures deficit  Full load EGR-rate limited by EGR-cooling and turbo charger capability 	<ul style="list-style-type: none">  Higher EGR-rate at same λ in all map areas possible  "clean" EGR (no soot, HC contamination)  Near perfect EGR-distribution even at high EGR-rates ("HCCI" enabler)  High boost pressures with EGR possible  control of LP-EGR fraction less coupled to turbo charger control  Smaller necessary EGR-cooler / front radiator capacity through better use of charge air cooler  Higher breathing volume  Measurement of LP-EGR fraction difficult (when necessary using HP EGR in Addition)  Pressure ratio limited by compressor inlet temperature  Acid condensation in the compressor / intake area

Fig. 19: Comparison of LP and HP EGR-Boost Systems

Based on these results EGR-systems will enable Diesel engines to breathe even more exhaust than today. LP EGR-systems will allow lower NOx emissions without any aftertreatment, which will help to keep system costs, weight and complexity down, figure 19. Adding a 2nd cooling stage is lowering NOx by smaller air intake temperatures. To optimise the best configuration depending on the situation in the vehicle is the task how to compromise between the parameters mentioned in figure 19. The single stage cooled LP EGR-system offers the most advantages based on the number of points and parameters.

Configuration	Reduction potential		Dynamics	weight	packaging	Contamination	Costs
	NOx	CO2					
HP-EGR cooled VTG EGR - DOC - DOC	Baseline						
HP-EGR highly cooled VTG EGR - DOC - DPF	+	-	⊙	-	-	-	-
HP-EGR 2-stage cooled VTG EGR - DOC - DPF	++	-	⊙	--	--	-	--
LP-EGR 1-stage cooled VTG EGR - DOC - DPF	++	⊙	+	⊙	-	+/-	-
LP-EGR 2-stage cooled VTG EGR - DOC - DPF	+++	⊙	+	--	--	+/-	--
UREA-SCR System EGR - DOC - DPF - SCR	+++	-	⊙	---	---	⊙	---

Fig. 20: Comparison of Future Emission Concepts, peak power output is constant

The established HP EGR-system offers advantages like compact packaging, low compressor intake temperatures even at high power outputs, and a low exposure of components to water and acid. The thermodynamic disadvantages have been explained and limit the HP-capabilities significantly.

The LP EGR-System, just enabled by the DPF, is new and seem to consume package volume, which can be limited by smart designs like closed coupled filters and catalysts. Water and acid precipitation are subject to current development to limit or exclude their impact in the future.

References

- /1/ Bartsch, P.; Gutmann, P.; Kammerdiener, T.; Weissbäck, M.;
- The Future Passenger Car Diesel Engine – Emission Reduction Combined with Excellent Driving Characteristics
- 26th International Vienna Engine Symposium, 2005
- /2/ Ruhkamp, L.; Krüger, M.;
- Measures for Further Reduction of Raw Emissions of HD-Diesel-Engines
- 26th International Vienna Engine Symposium, 2005
- /3/ Enderle, C.; Breitbach, H.; Paule, M.; Keppeler, B.
- Selective Catalytic Reduction with Urea – The Most Effective Nitrous Oxide Aftertreatment for Light Duty Diesel Engines
- 26th International Vienna Engine Symposium, 2005
- /4/ Weber, O.
- Ursachen fuer die Ablagerungsbildung in Abgaswärmeübertragern von Verbrennungsmotoren
- Dissertation RWTH Aachen, 1990

Amerika

BorgWarner Turbo Systems

3800 Automation Avenue
Auburn Hills, MI 48326/USA
Telefon: ++ 1248 754 9600
Telefax: ++ 1248 754 9397

BorgWarner Turbo Systems

P.O. Box 15075
Asheville, NC 28813/USA
Telefon: ++ 1828 684 40 00
Telefax: ++ 1828 684 41 14

BorgWarner Brasil Ltda.

Estrada da Rhodia Km 15
P.O. Box 6540
13084-970 Campinas-SP/Brasil
Telefon: ++ 55 19 37 87 57 00
Telefax: ++ 55 19 37 87 57 01

Europa

BorgWarner Turbo Systems GmbH

Marnheimer Straße 85/87
67292 Kirchheimbolanden/Germany
Telefon: ++ 49 (0)63 52 4 03-0
Telefax: ++ 49 (0)63 52 4 03-18 66

**BorgWarner Ltd.
Turbo Systems Division**

Bradford BD4 6SE
West Yorkshire/UK
Telefon: ++ 44 12 74 68 49 15
Telefax: ++ 44 12 74 68 96 71

BorgWarner France SAS

23 bis, avenue de l'Europe
78400 Chatou/Frankreich
Telefon: ++ 33 1 3015 94 44
Telefax: ++ 33 1 3015 94 40

**BorgWarner Turbo Systems
Poland Sp. z o.o.**

Jasionka 950
36-002 Rzeszów/Poland
Telefon: ++ 48 1 78 50 88 00
Telefax: ++ 48 1 78 50 88 34

BorgWarner Turbo Systems Kft.

Táncsics Mihály út 111.
H-2840 Oroszlány/Ungarn
Telefon: ++ 36 34 562-300
Telefax: ++ 36 34 562-301

Asien

BorgWarner Turbo & Emissions Systems

Shin-Yokohama Turbo Branch
Sumitomo Fudosan
Shin-Yokohama Bldg.10F
2-5-5, Shin-Yokoyama, Kouhoku-ku
Yokohama-shi, Kanagawa
222-0033 Japan
Telefon: ++ 8145 470 6850
Telefax: ++ 8145 470 6811

**BorgWarner Automotive
Components (Ningbo) Co., Ltd.**

Turbo & Emissions Systems
No.188, Jingu Zhong Rd. (West)
Yinzhou District
Ningbo P.R. China 315104
Telefon: ++ 86 (0)574-8819-0930
Telefax: ++ 86 (0)574-8302-5883

SeohanWarner Turbo Systems Ltd.

Eoyeon-Hansan Industrial Park
893-1, Eoyeon-ri, Cheongbuk-myeon
Pyongtaek-shi, Kyonggi-do
451-833 Korea
Telefon: ++ 82 (0)31-680-00 01
Telefax: ++ 83 (0)31-683-929

www.borgwarner.com



**BorgWarner
Turbo & Emissions Systems**

feel good about driving