

R. Sauerstein^a
R. Dabrowski^b
M. Becker^c
H.-P. Schmalzl^d
R. Christmann^a

The Dual-Volute-VTG from BorgWarner – A New Boosting Concept for DI-SI engines (2009)

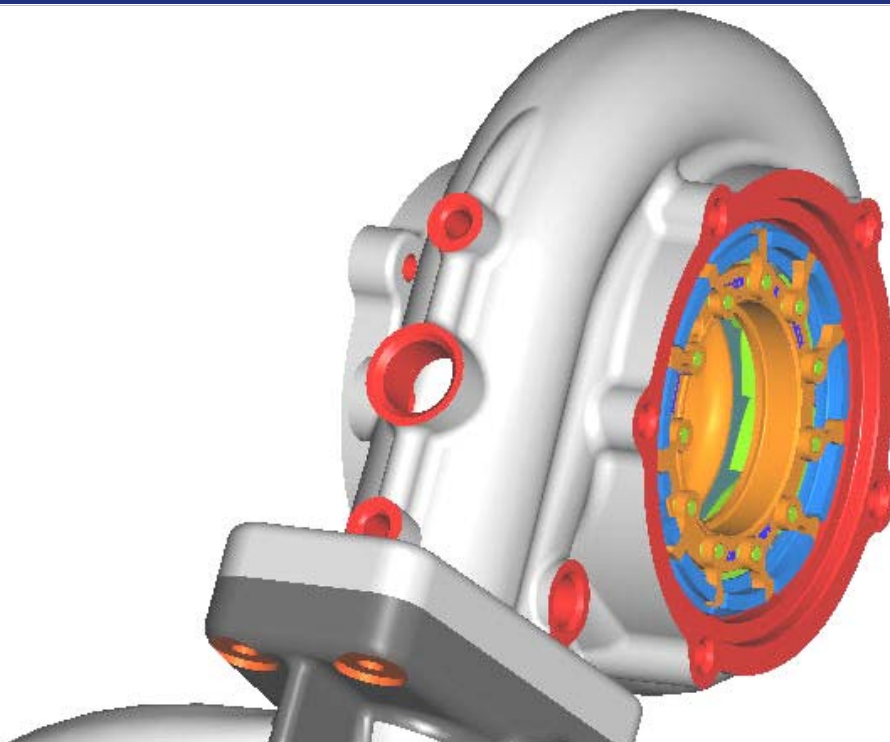

- a BorgWarner Turbo Systems
- b Hochschule Mannheim, TurboAcademy
- c BorgWarner Inc. Engine Systems Group
- d BorgWarner Inc.



KnowledgeLibrary



BorgWarner
Turbo Systems

Introduction

A concept strategy consisting of exhaust gas turbocharging, direct injection and variable valve timing gear has become established as a compromise between CO₂ savings potential and effort in the last few years in the case of SI engines.

The increasing demand for optimizing the overall system requires a continual improvement in the components and how they interact with each other. The required increase in the boost ratio in the case of downsizing concepts means that this is becoming more and more important.

This results in new requirements in respect of the characteristics and performance capability of the components:

- Coping with combustion
 - Reliable ignition at high boost pressures
 - High-performance ignition systems for lean mixtures / mixtures diluted by exhaust gas
 - Avoidance of harmful work cycles
 - High conversion rates
- Flexibility of the charge cycle
 - Adaptation of timing optimum for operating point
 - Increase in cylinder recharge
 - Reduction in cylinder residual gas mass
 - Reduction in charge cycle losses
 - Reduction in cylinder charge temperature
 - Adaptation of the turbocharging process optimum for operating point by variable pressure build-up behavior
- Extending the operating temperatures by high-temperature materials
- High / low-pressure EGR to improve emissions and limit the exhaust temperature

BorgWarner, being a systems supplier, pursues a policy of ongoing optimization of the relevant components exhaust gas turbocharger, variable valve timing gear, EGR modules and ignition technologies in order to comply with future emission requirements.

A new boosting concept for 4-cylinder DI-SI engines that attempts to unite the advantages of variable turbine geometry (VTG) with those of consistent separation of exhaust routing is presented below.

Requirements and degrees of freedom for exhaust gas turbocharging on an SI engine

Owing to the differing throughput characteristics of turbo-machine and piston machine, thermodynamic coupling of turbocharger and internal-combustion engine leads to known problems in respect of the engine-related stationary and transient behavior. When designing turbocharging systems for SI engines, these problems occur to a greater extent owing to the higher throughput spread required.

A pressure ratio p_3/p_4 occurs which can be converted to a certain boost pressure p_2 in accordance with the first turbocharger main equation (equation 1) depending on the exhaust flow throughput by the engine.

$$\pi_V = \frac{p_2}{p_1} = \left[1 + \frac{\dot{m}_T}{\dot{m}_V} \cdot \frac{T_3}{T_1} \cdot \frac{c_{p,A}}{c_{p,L}} \cdot \eta_T \cdot \eta_V \cdot \eta_{mT} \cdot \eta_{mV} \cdot \left(1 - \left(\frac{p_4}{p_3} \right)^{\frac{\kappa_A - 1}{\kappa_A}} \right)^{\frac{\kappa_L}{\kappa_L - 1}} \right]^{\frac{\kappa_L}{\kappa_L - 1}} \quad (\text{equation 1})$$

Smaller fixed-geometry turbines with wastegate control which allow high turbine pressure ratios and, consequently, high boost pressures even at low exhaust gas flow rates owing to their pressure build-up behavior are used today on turbocharged passenger car SI engines to implement an effective torque build-up and a good dynamic driving behavior. However, such a design with increasing full-load engine speed and, in particular, in the nominal output range, leads to an undesirably high pressure level p_3 upstream of the turbine despite the control facility at the exhaust end. The negative flushing gradient ($p_{2S} - p_3$) which occurs in this case results in, besides the increased charge cycle work $p_{mi, LW}$, a high residual gas content x_{RG} which significantly increases the knocking tendency and results in the upward fuel consumption spiral with retarded ignition point, high exhaust gas temperature T_3 and the corresponding need to enrich the fuel in order to protect the components against heat.

In the reverse, turbines with high absorption capacity permit, admittedly, good effective engine efficiencies at high full-load speeds but are not able to provide satisfactory starting torques above all for SI engine applications.

The conflicts discussed between attractive low-end torque and good specific fuel consumption at nominal power cannot be solved with fixed-geometry turbochargers. Despite the more difficult temperature boundary conditions by comparison with the diesel engine, this fact led to the series introduction, for the first time, of a variable turbine geometry (VTG) by BorgWarner [1] in the SI engine passenger car segment as well.

The blades in the guide frames (Figure 2.1) vary the build-up behavior by changing the angle of incidence of the absolute flow into the turbine rotor so as to make available an adequate turbine size in a broadly spread area of the mass flow throughput by the engine. This means that the VTG acts directly on the actual core problem of coupling piston machine and turbo-machine. Moreover, it has the energy-related advantage that the complete exhaust gas mass flow is routed via the turbine rotor. This raises the mass flow ratio in the first turbocharger main equation (see Figure 2.2) and has a positive impact on the turbine efficiency.

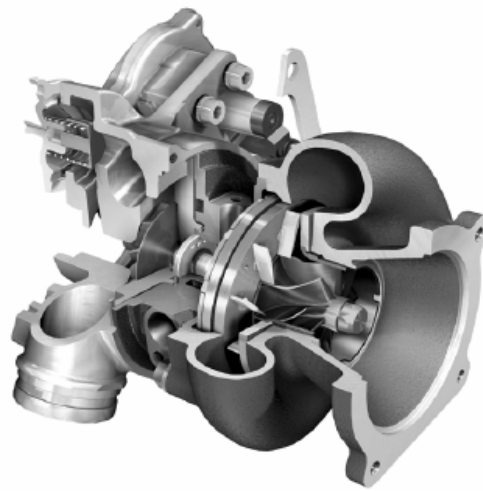

Figure 2.1: Turbocharger with variable turbine geometry [2]

One other focus in optimizing the interplay between SI engine and turbocharger is to minimize the feedback of the charging device on the engine work process. Central importance is attached in this case to the configuration and the geometrical design of the combination of exhaust gas manifold and turbine housing. In order to reduce the impairment of the charge cycle by the pressure surge of the relevant cylinder neighboring in the ignition sequence shortly after “Outlet opens”, an ignition sequence manifold and dual-flow turbine housing [3] are used, amongst other things, on turbocharged 4-cylinder SI engines. The associated decoupling of the exhaust gas pulses achieves a positive dynamic flushing pressure gradient over the individual cylinder during

the valve overlap phase so that, in the case of DI-SI engines, in principle, a “scavenging” charge cycle is possible.

In addition, in the case of dual-flow housings, the kinetic energy contained in the exhaust gas is better used to increase the useful enthalpy gradient at the turbine (surge boosting) owing to the smaller line cross-sections in the case of scroll separation. In order to further-increase the influence of surge boosting and, thus, the available energy at the turbine, it is possible, with the aid of the dual-flow housing (see Figure 3.1.1), to move scroll separation and, thus, the pressure pulsations contained in the exhaust gas as far as directly against the turbine rotor.

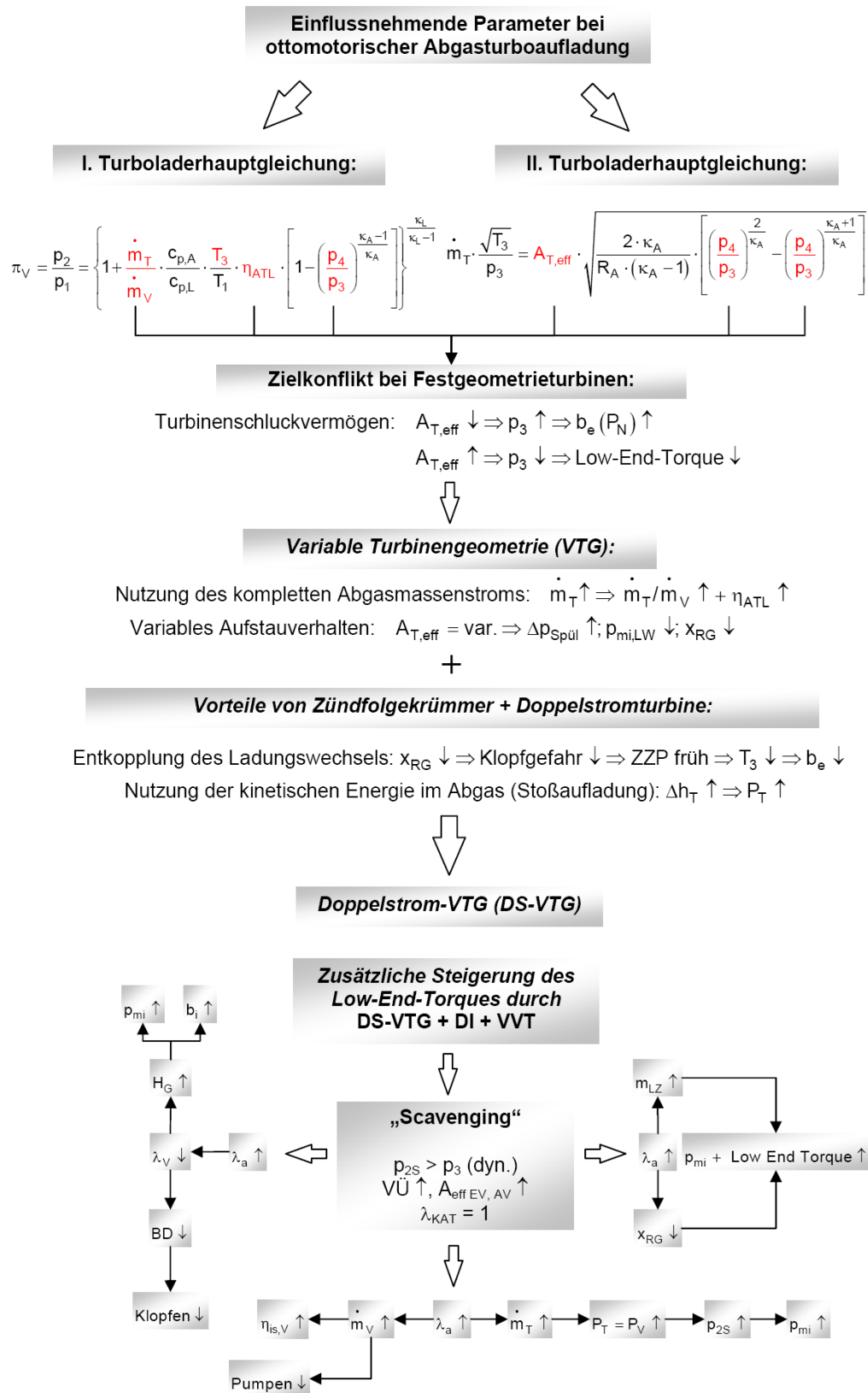

Figure 2.2: Mechanisms of action in the case of SI engine turbocharging

The advantages for the SI engine working process, resulting from variable pressure build-up behavior and consistent exhaust routing, lead to a logical further development in the form of uniting the functions of the two design principles (dual-volute VTG).

Moreover a combination of multi-scroll turbine housing, VTG and variable valve timing gear (VVT) would appear promising for a further increase in the low-end torque. Various investigations have already indicated that, in some cases, the torque in the lower engine-speed range can be boosted by up to 40 % [4], [5] by “scavenging” if dual-flow housings are used and simple VVT systems, e.g. camshaft phase adjusters at the inlet and outlet ends.

Adequately large effective valve opening cross-sections and a positive, dynamic flushing gradient applied across the cylinders during the valve overlap phase are required for a flushing charge cycle. The far higher air demand λ_a which occurs during “scavenging” improves both the SI engine work process and the operating behavior of the turbocharger (see Figure 2.2) in this case. On the one hand, through-flushing with fresh air, besides the clear reduction in residual gas content x_{RG} , contributes towards an increase in recharge mass flow rate m_{LZ} , and, on the other hand, the turbine mass flow and, thus, ultimately the charge pressure can be increased or the pressure upstream of the turbine can be reduced for the same turbine performance P_T .

Design and properties of the dual-volute VTG

Surge charging and multi-scroll turbine housings

Both the turbine efficiency and the turbine output can be influenced greatly by the design of exhaust gas routing through to the turbine rotor. It is possible to distinguish between build-up charging and surge charging depending on the design of the exhaust gas manifold and that of the turbine housing (volumes, diameters and lengths). The latter has become established to an increasing extent in the case of passenger cars, among them, particularly in the case of SI engines. The geometrically short link of the turbine to the engine allows a higher charge of kinetic exhaust energy to be transmitted to the rotor. However, the exhaust gas pulsation occurring over a work cycle and the resultant unequal application of the pressure on the turbine do have a disadvantageous effect. This leads to incorrect incident flow to the rotor as the result of the turbocharger speed which does not follow equally quickly and thus leads to a reduction in turbine efficiency. Despite impaired turbine efficiency, it is ultimately possible to raise the turbine output with the risen available exhaust gas energy, allowing advantageous transient behavior (abrupt load change, acceleration) and high turbine outputs at low speeds (low-end torque).

A more extensive increase in utilization of exhaust gas energy can be achieved by using a multi-scroll turbine housing instead of a single-scroll turbine housing. On these, the aim is to achieve separate exhaust gas routing of the individual cylinders so that the pressure waves are routed to a point directly in front of the turbine rotor wherever possible [6].

Separate-scroll turbine housings are frequently technically implemented in the form of twin-scroll housings on which both scrolls are arranged adjacently and thus supply the exhaust gas over the entire circumference of the rotor. The principle may involve disadvantages in efficiency since the rotor incident flow adjacently and intermittently causes differing section pressure conditions. The resultant disturbance to incident flow or partial application of pressure to the turbine rotor can be reduced by creating, in the design, a transfer compartment in the nozzle area upstream of the rotor. The associated mixing of exhaust gas pulsations and mass flow rates may lead to reductions in efficiency owing to the dissipation losses.

Besides this type of construction, dual-volute housings on which the flow per volute is over part of the circumference are also used. The volutes are separated from each other by a separating web which, similar to the separating lug on single-scroll flow housings – projects as far as the rotor. Figure 3.1.1 schematically shows the design differences between both versions.

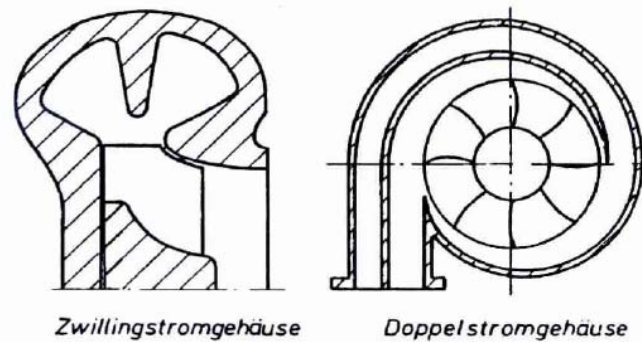

Figure 3.1.1: Multi-scroll turbine housings [7]

In the case of dual-volute housings, separation between the scrolls leads to different thermodynamic states in two adjoining blade channels if the rotor moves over one of the separating lugs. The resultant application of pressure which changes greatly may lead to critical vibration excitations of the blades, which is why, in the past, twin-flow housings were given preference over dual-volute housings. A reduction in unequal application of pressure over the circumference of the rotor can be achieved by positioning guide vanes upstream of the rotor. This design variant is known primarily from the commercial vehicle sector.

The dual-volute VTG

The advantageous operating behavior of dual-volute or twin-flow turbines at low engine speeds and the variable pressure build-up behavior of the VTG at moderate to high engine speeds have each been described several times as a separate measure [1], [3], [4]. One obvious combination of surge charging, dual-volute or twin-flow turbine and variable guide vanes to utilize the synergism effects has already been investigated in simulation calculations. The combination of twin-flow turbine housing and variable guide vanes has proven to be superior in this case [8]. The above-described transitional chamber between the two scrolls as far as the turbine rotor is increased in size if using variable guide vanes in the case of twin-flow housings. This increases the capability of pressure equalization or reduction in pulsation between both scrolls. A dual-volute turbine, for reasons relating to its principle, affords advantages over a twin-flow turbine owing to the incident flow over the entire width of the rotor. For this reason, it was decided to develop and analyze a dual-volute VTG in a potential analysis.

The specifications contained the following essential requirements:

- Consistent scroll separation in the exhaust gas manifold and turbine housing

- Implementing scroll separation either on entry into the guide vanes or on exit to the guide blades
- Compact design of the turbocharging assembly of the turbine and cylinder head through to the guide vane assembly of the turbine
- Maximum exhaust temperature $T_3 = 980\text{ }^{\circ}\text{C}$
- Modular design so as to incorporate existing series components

Figure 3.2.1 below shows a view of the twin-volute VTG together with optimized exhaust gas manifold.

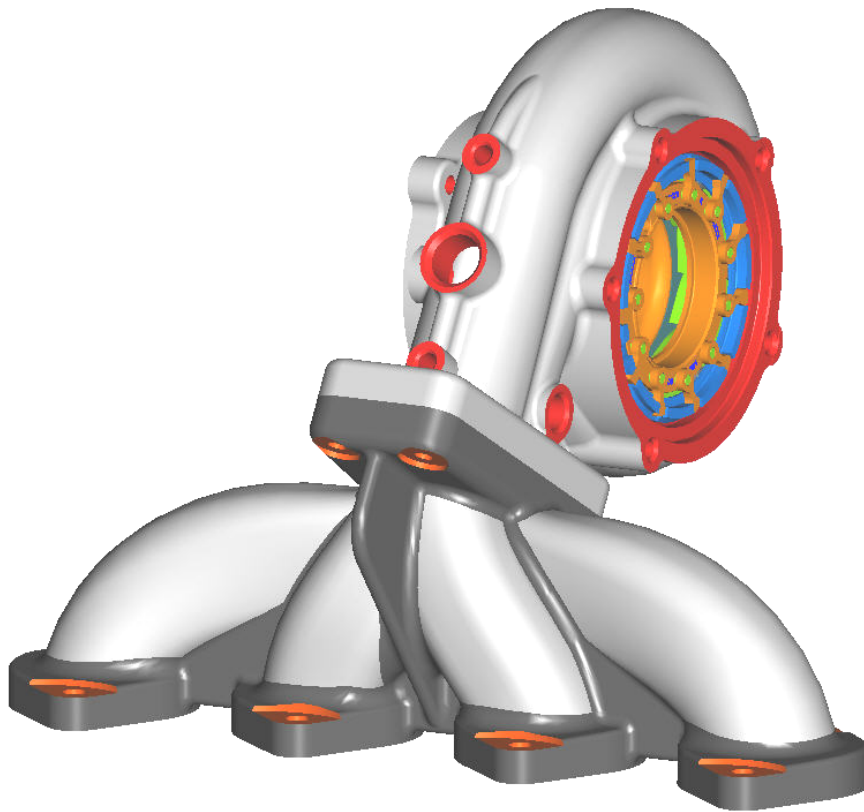

Figure 3.2.1: View of dual-volute VTG with exhaust gas manifold

It can be clearly seen that a joint gas supply flange was selected in order to implement a compact design. Details of the aerodynamics in the turbine housing can be seen in Figure 3.2.3. Both flow scrolls route the exhaust gas through a deflection angle of 180° in each case to the

guide vanes before it is routed through the guide blades to the turbine rotor. The view clearly indicates that the guide blades in this position of rotor incident flow impress a high circumferential component for high turbine outputs.

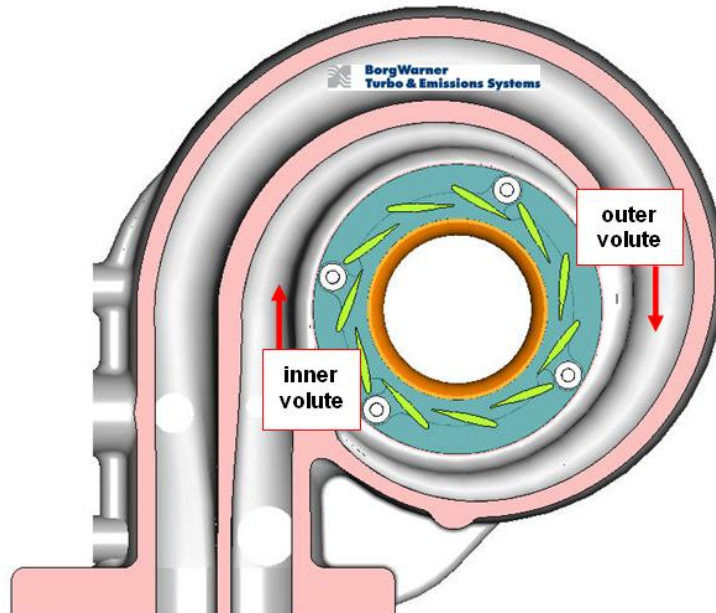

Figure 3.2.2: Deflection through a dual-volute-turbine housing with VTG guide vanes

The illustration below shows a component listed with integrated bores for accommodating the measuring systems.



Figure 3.2.3: View through dual-volute turbine housing with VTG guide vanes

Test engine and boundary conditions

Test engine

The basic engine selected for the tests was a modified SI engine with direct injection and camshaft phase adjusters at the inlet and outlet sides Table 1 provides an overview of the most important engine details.

Table 1: Technical data of the test engine

| | | |
|--------------------------|------------|--|
| Engine type | - | In-line 4-cylinder |
| Ignition sequence | - | 1-3-4-2 |
| Combustion method | - | DI-SI engine |
| Valve timing gear | - | DOHC, camshaft phase adjuster at inlet and outlet camshaft |
| Compression ratio | - | lowered to 9.5 |
| Specific output | kW/l @ rpm | 85@ 5500 |
| Max. medium pressure pme | bar @ rpm | 21 @ 1500-4800 |

Investigated turbocharger and exhaust gas manifold variants

Analysis of various charging systems also includes correspondingly designed exhaust gas manifolds. A separated-scroll exhaust gas manifold the combines the scrolls of cylinders 1+4 and 2+3 and implements the separation by the turbine housing until directly upstream of the guide blades was set up in order to represent decoupling of pressure pulsation next in the ignition sequence in the exhaust gas for the dual-volute VTG. This dual-volute manifold was also used for the single-flow VTG in order to investigate the influence of a scroll-separated manifold in conjunction with the exhaust gas build-up behavior in the case of closed guide blades. Moreover, a single-scroll congestion-type manifold was investigated with the VTG in order to analyze the lack of decoupling of the exhaust gas pulsations. The dual-volute VTG was designed for the same turbine throughput characteristic as the single-scroll VTG.

Table 2: Overview of the turbocharger variants examined

| Turbocharger variant | Turbine | Exhaust gas manifold | Designation |
|----------------------|-------------------|---|-------------|
| 1 | Dual-volute VTG | Dual-volute | DVTG+DSK |
| 2 | Dual-volute VTG | Dual-volute, with scroll connection | DVTG+DSK+FV |
| 3 | Single-scroll VTG | Dual-volute | VTG+DSK |
| 4 | Single-scroll VTG | Congestion-type manifold, single-scroll | VTG+SK |

Test boundary conditions, measured data acquisition and analysis

The test engine was equipped with a high-pressure and low-pressure indication system in order to determine the dynamic pressures in the exhaust and intake system and to monitor the engine for knocking. The characteristic parameters obtained with the indication system were then edited by computer using pressure progression analysis in order to determine fundamental assessment variables of the charge cycle.

Essential results of this calculation shown here are as follows:

- Residual gas content x_{RG}
- Fresh air mass in the cylinder after Inlet Closes m_{LZ}
- Mass flow functions over the inlet and outlet valves
- Dynamic flushing radiant

A universal controller for controlling all relevant actuators was available in order to be able to implement the degrees of freedom resulting from camshaft phase adjusters and exhaust turbocharging in the engine. The overall system of engine and turbocharger is operated under defined adjusting conditions in order to guarantee reproducible results:

- Target intermediate pressure: 21 bar (to be achieved as early as possible)
- Nominal output: 85 kW/l
- Air ratio: $\lambda = 1$ (wherever possible)
- Maximum exhaust gas temperature: $T_3 = 950 \text{ }^\circ\text{C}$ (enrichment if required)

- Ignition point: efficiency-optimum for maximum intermediate pressure or limited by knock limit
- Minimum air ratio: $\lambda = 0.75$ (output reduction if necessary)
- In the case valve timing variations: control of the air ratio by lambda probe upstream of catalytic converter

Measured results and analysis

Analysis of the full-load behavior with no variation in engine timing

A first step comprised the investigations with minimum valve overlap in order to preclude the transverse influence of the flushing charge cycle (“scavenging”) at low engine speeds. The following Figure 5.1.1 provides an overview of important engine characteristic parameters at full load.

All charger variants achieve the required rated output, but there are clear differences at low engine speeds. The dual-volute VTG with and without scroll connection features an intermediate pressure advantage over the single-scroll VTG constantly. At the very lowest engine speeds in particular (1000, 1200 rpm), it is possible to boost the intermediate pressure by approx. 0.7 bar with this variant, and the advantage at 1800 rpm is approx. 2 bar p_{me} . The DVTG+DSK achieves the target intermediate pressure as early as 1800 rpm whilst the VTG variant with congestion-type manifold does not reach this value until upwards of 2500 rpm.

The air ratio curve follows the maximum permitted exhaust gas temperature. There are lower exhaust gas temperatures on the variants with scroll separation than is the case on the variant with congestion-type manifold. Splitting the exhaust gas heat flow over two scrolls and the associated, increased wall surface area in the exhaust-gas line means a lower measured temperature. Owing to this geometry-related advantage, the limit temperature of 950 °C averaged over both scrolls is only reached at the rated output point without requiring protective component enrichment with the DVTG+DSK. The other variants achieve the limit temperature between 4500 and 5500 rpm and thus have a moderate enrichment requirement.

One further influencing parameter on the exhaust-gas temperature shown is the ignition angle that reflects the position of the knock limit. Timing retard which tends to be required at low engine speeds results from the load which is higher here with the DVTG+DSK. The further progression indicates a clear advantage up to approx. 3° crank angle over the single-scroll variant with congestion-type manifold, and this advantage drops with increasing engine speed.

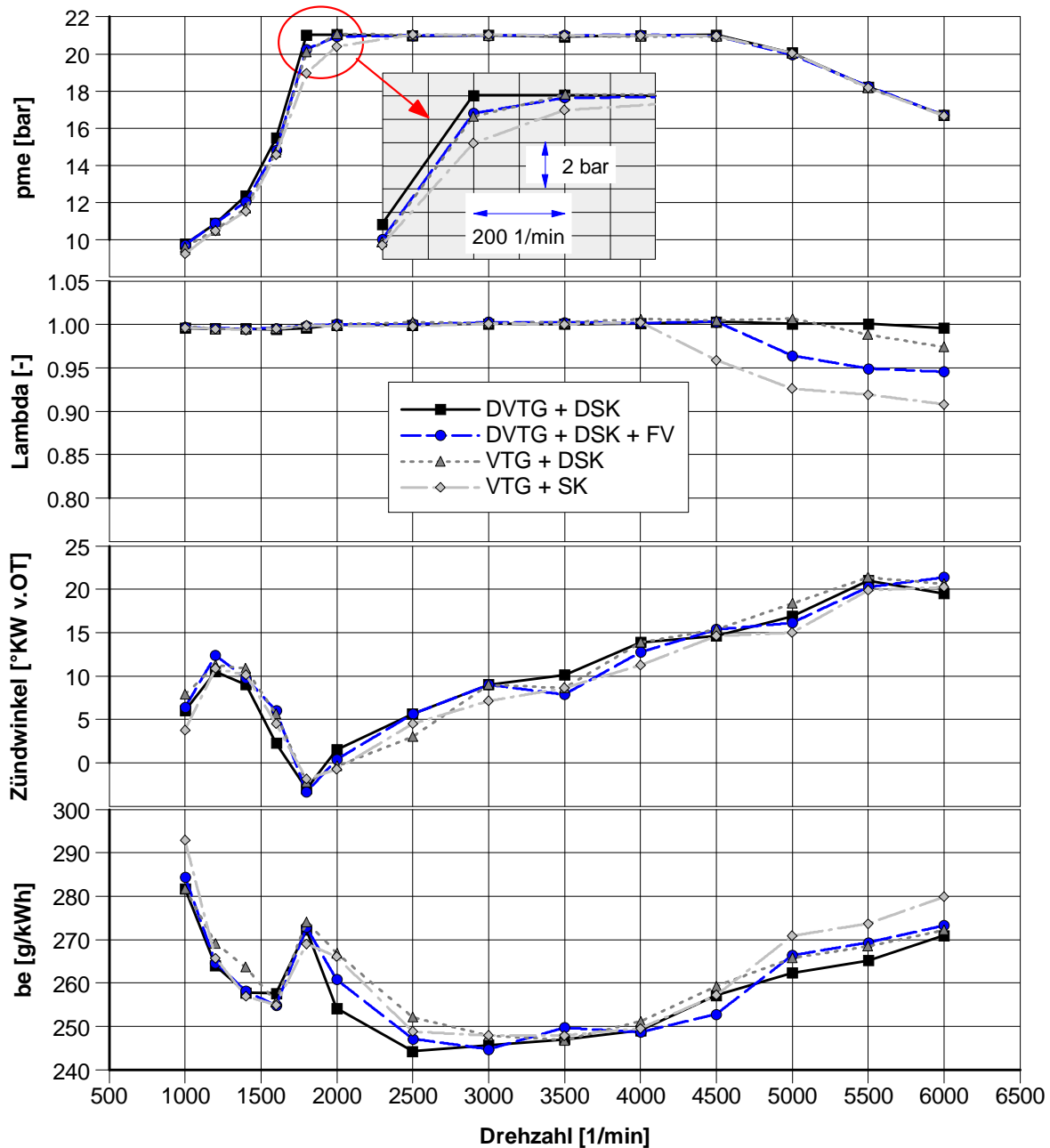

Figure 5.1.1: Characteristic engine parameters of the turbocharger variants investigated at full load

The curve of specific fuel consumption b_e indicates the lowest values virtually up to 4000 rpm for the DVTG+DSK – despite the intermediate pressure which is higher at lower engine speeds. As of an engine speed of 4000 rpm, the consumption rises on all variants, and, here as well, the DVTG+DSK achieves minimum values. Besides the low enrichment demand, one supporting factor in this case is the exhaust gas pressure upstream of the turbine which is reduced

particularly at high engine speeds, occurring as the result of the variable pressure build-up capacity and utilization of the full exhaust gas mass flow [4]. The overall level thus lies beneath realistic boundary conditions (defined throttling of compressor and back-pressure at the exhaust gas end) in the target range of modern SI engines.

The influences from the charge cycle are discussed in the following Section.

Analysis of the charge cycle at full load without valve overlap

A more detailed analysis was conducted in order to clarify the influence of the various turbocharger variants on the charge cycle. This involved editing and representing the data obtained with the high-pressure and low-pressure indication systems using a charge cycle analysis program.

The following Figure 5.2.1 explains the charge cycle-end operating behavior of the variants. The curve of the average flushing gradient dp_{Cyl} (pressure gradient across cylinder: $p_{2S} - p_3$) has slightly negative values up to 2000 rpm, whereby, here as well, the advantages of the DVTG+DSK can be seen. Despite the maximum intermediate pressure of this variant, it is obviously possible to reduce the exhaust gas pressure upstream of the turbine and nevertheless provide a high turbine output, indicating successful use of the increased kinetic exhaust gas energy in the case of consistent scroll separation through to the guide vanes of the VTG. As of an engine speed of 2000 rpm, the DVTG+DSK has an increased negative flushing gradient which lies above that of the other variants. 1-D simulation calculations indicated this behavior, which was able to be confirmed by this measurement [8]. Logical improvement of this behavior was able to be achieved by scroll connection, with the aid of which the flushing gradient up to the rated output point improves by approx. 250 mbar. The variants of the single-scroll VTG also show an improvement but it is significantly less than that of the variant with scroll connection.

We see a similar picture if we observe the indicated charge cycle work $p_{mi,LW}$. At moderate to high engine speeds, it can be clearly seen that scroll connection achieves an improvement of up to 0.6. The VTG variants with dual-volute or congestion-type manifold show virtually identical values, which indicates a subordinate influence of the exhaust gas manifold of the flushing gradient or on the charge cycle.

This behavior becomes transparent if we consider the residual gas content which has the lowest values in the case of the dual-volute VTG with and without scroll connection and which thus lies clearly below the residual gas level of the single-scroll VTG variants. It was initially assumed that

the residual gas content of the DVTG+DSK at low engine speeds has a similar curve as with investigations with a twin-flow housing [4], but at a somewhat higher level.

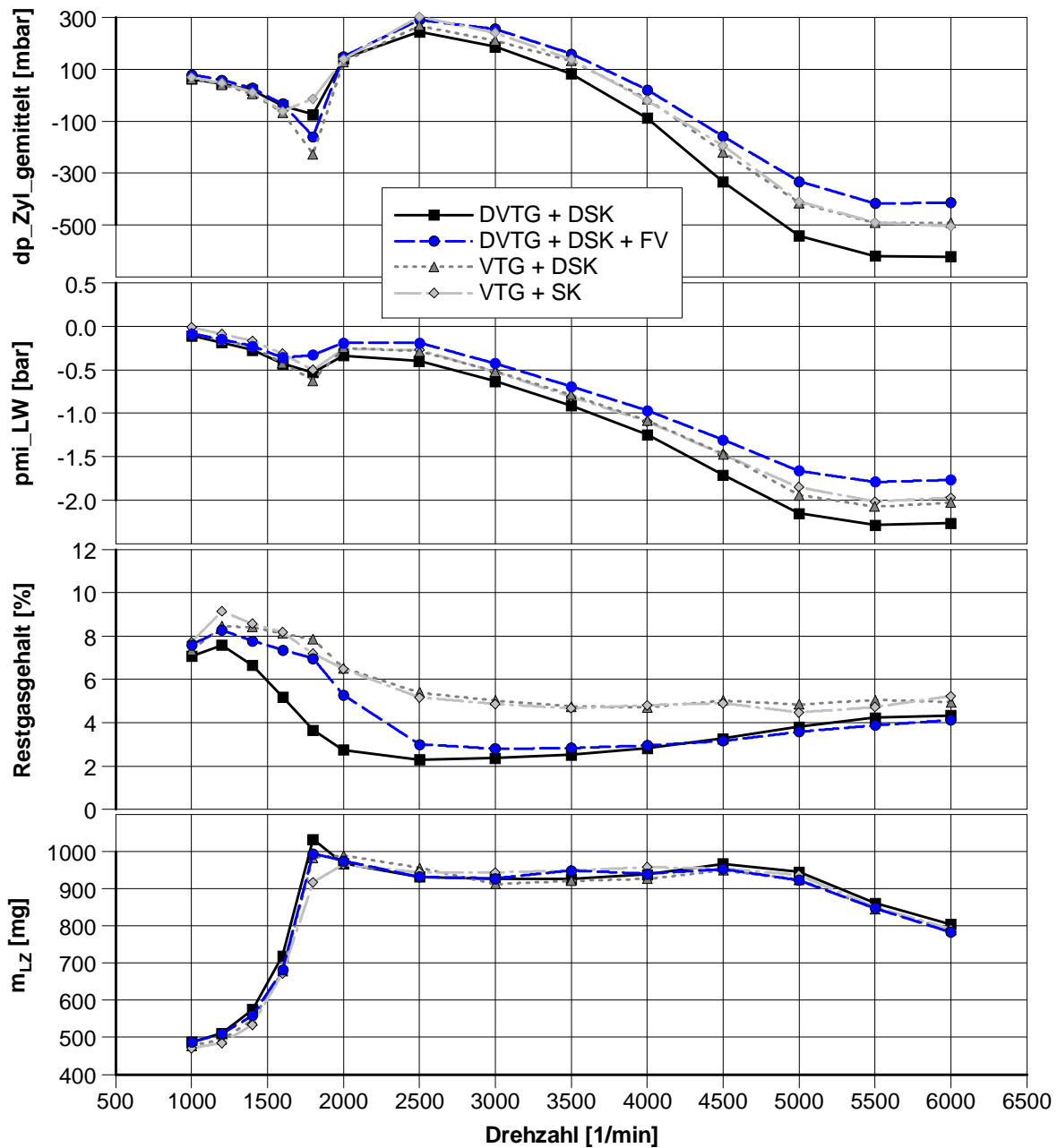

Figure 5.2.1: Charge cycle analysis of the investigated turbocharger variants

A closer consideration of the geometrical conditions in this operating range indicates that operation with closed guide blades provides maximum intermediate pressure in each case. However, at the same time, the low flow cross-section between the closed guide blades and the associated increased distance between guide blade outlet and turbine rotor causes crosstalk

between the individual scrolls in some cases. The level of implementation of scroll separation of turbine housing and exhaust gas manifold is reflected in the residual gas curves of all variants and thus follows the theoretical assumptions.

With increasing engine speeds, it is possible to lower the residual gas level at an early point and significantly down to approx. 2 % with scroll separation. The variant with scroll connection achieves a similar level, but approx. 500 rpm later. The strikingly low level at moderate to high engine speeds can also be explained by the geometrical conditions within the guide blades: the guide blades open increasingly as the engine speed increases, thus causing a reduction in the distance between the tips of the guide blades and the turbine rotor and thus causing more favorable conditions for scroll separation. The advantage of the scroll-separated turbine is reduced at high engine speeds but still exists. From this, we can derive that operation with scroll separation is practical at low engine speeds and that operation with scroll connection is practical at moderate to high engine speeds. The variants without scroll separation have the highest residual gas contents with almost 9 % and achieve 5 % at minimum.

Solely considering the averaged flushing gradient proves to be too imprecise [4] in order to state whether the preconditions for residual gas scavenging exist or not. Slightly negative values occur up to 2000 rpm, which apparently precludes the option of residual gas scavenging. However, a detailed consideration of the pressure curves in the intake manifold extracted from low-pressure indication and of the pressure curves upstream of the turbine allow differentiated statements, thus emphasizing the relevance of a consideration of the charge cycle at various times.

An integral assessment of the charge cycle can be made on the basis of the calculated fresh air mass in the cylinder m_{LZ} .

The dual-volute VTG with scroll separation achieves the highest cylinder fresh air mass, as is expected. Together with the lowest residual gas content, this thus provides ideal preconditions for lower susceptibility to knocking and, consequently, good engine efficiency.

Figure 5.2.2 which follows shows a detailed comparison of the static and dynamic flushing gradient at various times. In this case, the charge cycle of all variants was analyzed at 1600 rpm and at full load. It can be clearly seen how, on the one hand, scroll separation leads to masking of the cylinder next in the ignition sequence and, on the other hand, we can see the pressure boosting in the ejection stroke. The lower part-diagram shows the dynamic flushing gradient at various times and the valve lifting curves. The flushing gradient averaged from the dynamic pressure curves is also shown.

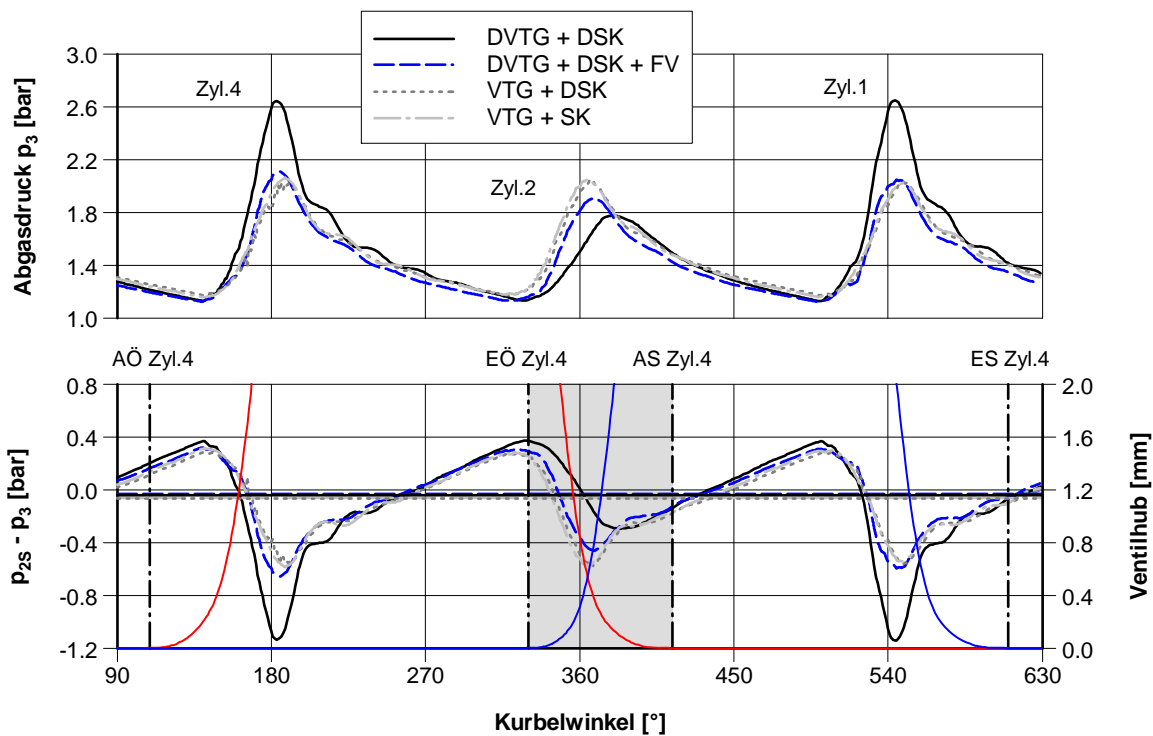

Figure 5.2.2: Charge cycle at 1600 rpm on the investigated turbocharger variants with minimum valve overlap

In the area of valve overlap (grayed area), it can be seen that only the variant DVGT+DSK has, in some cases, positive values of dynamic flushing gradient whilst all other variants have virtually completely negative values. It is clearly indicated that slightly negative values in the static flushing gradient can certainly still have a positive effect in a dynamic consideration resolved over the crankshaft, shown here in the significant reduction in residual gas (see Figure 5.2.1).

A similar comparison at 5500 rpm and full load is shown in Figure 5.2.3. Here, the masking of the cylinder next in the ignition sequence and the pressure boost in the ejection stroke can be seen even more clearly on the DVTG+DSK. The variant with scroll connection also differs from the other variants – other than at 1600 rpm. The averaged exhaust gas pressure upstream of the turbine which is also drawn in clearly shows the highest mean value on the dual-volute VTG without scroll connection and the lowest mean value on the dual-volute VTG with scroll connection. The variants with single-scroll turbine housing lie in-between. The dynamic flushing gradient at various times in the area of valve overlap is reflected by the residual gas curve (see Figure 5.2.1): both areas of the dual-volute VTG have the lowest negative values, and the variants with single-scroll turbine housing lie clearly above this.

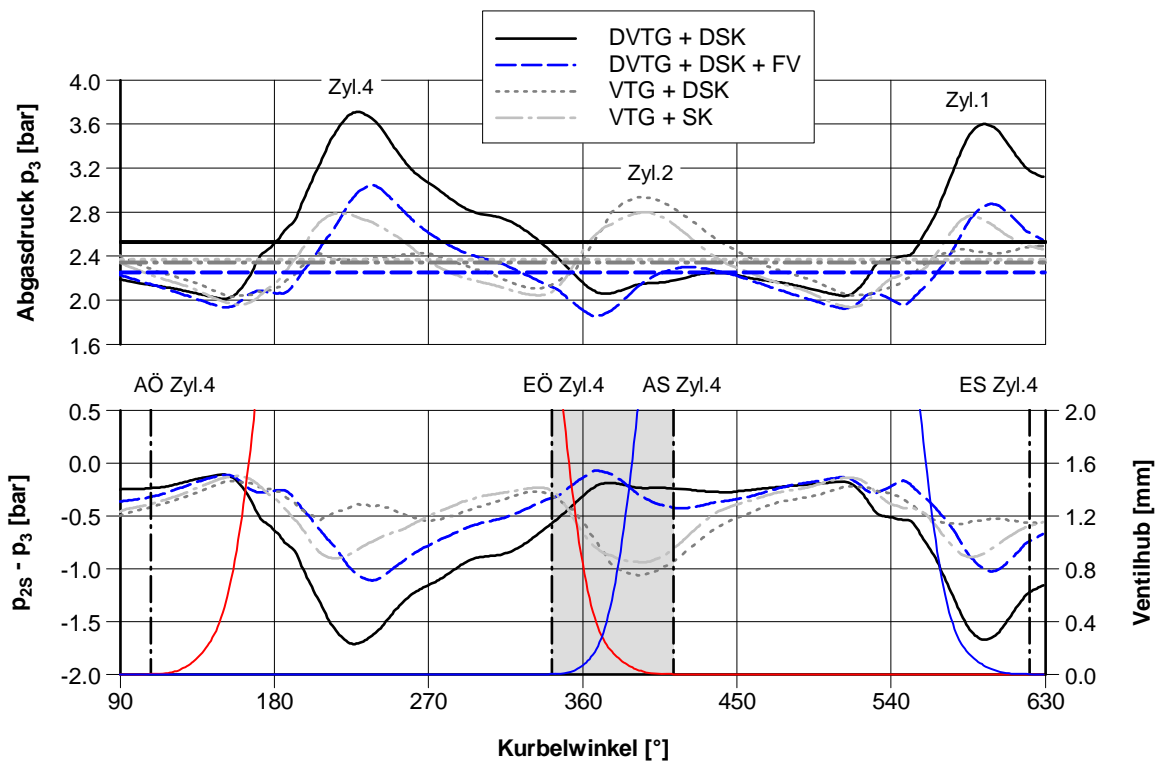

Figure 5.2.3: Charge cycle at 5500 rpm of the turbocharger variants investigated with minimum valve overlap

The effect of using the various turbine variants in the compressor characteristic map is shown in Figure 5.2.4. It is clearly indicated that, when the maximum charge pressure is reached (compressor pressure ratio P_{i_Vt} at approx. 2.0), both variants of the dual-volute VTG require lower compressor pressure ratios owing to the lower residual gas content and that the operating curve is shifted towards better compressor efficiencies. In the range of moderate to maximum engine speeds, the pressure ratio for overcoming the flow losses increases again for all variants, whereby the dual-volute VTG with scroll connection features the lowest charge pressure demand. This also offers here the option of relocating the operating points to better compressor efficiencies. Moreover, the compressor performance and, thus, also the turbine output can be reduced.

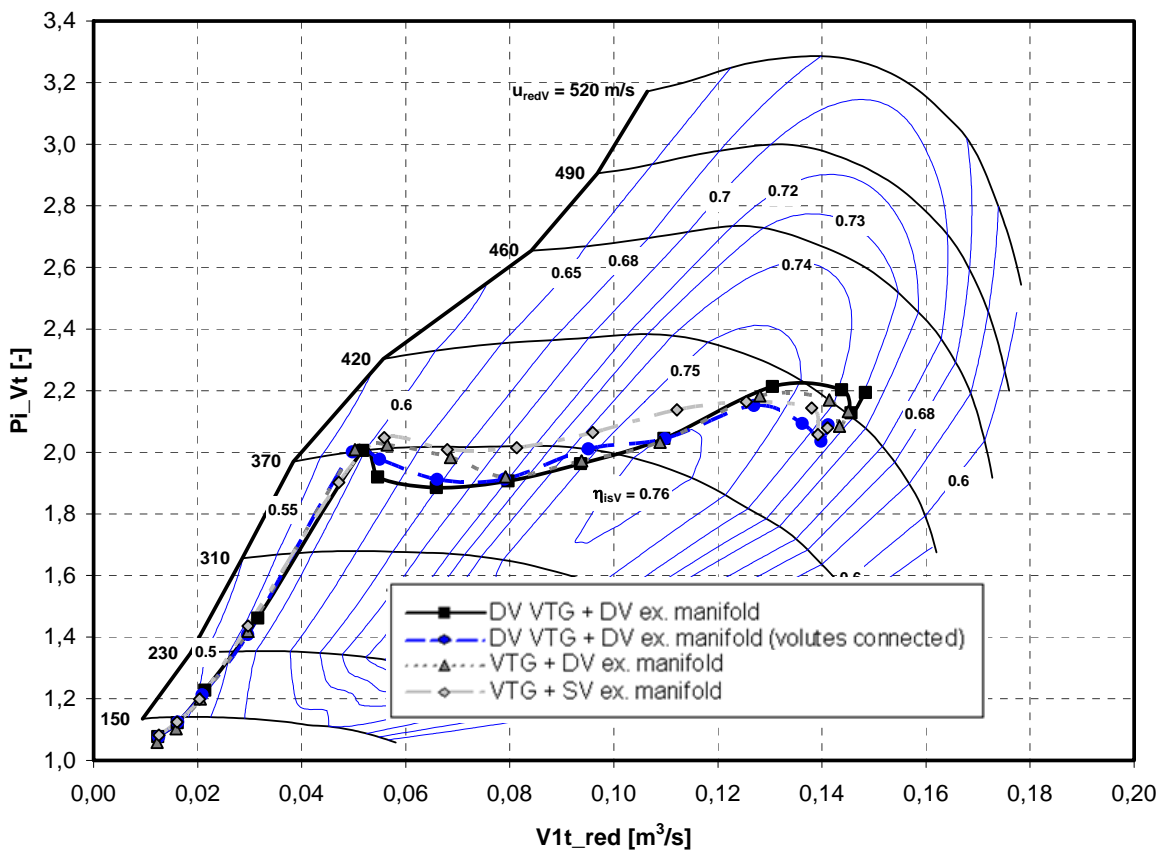

Figure 5.2.4: Full-load operating curves of the turbocharger variants investigated in the compressor characteristic map

Analysis of full-load behavior with valve overlap

The next step was to conduct investigations with minimum and maximum valve overlap in order to analyze the influence of the flushing charge cycle (“Scavenging”) at low engine speeds. Figure 5.3.1 below provides an overview of essential engine characteristic parameters of the variants dual-volute VTG with scroll connection by comparison with the single-scroll VTG with congestion-type manifold. With maximum valve overlap, the last variant is not able to boost the torque at lowest engine speeds and even a reduction of approx. 2 bar p_{me} is recorded. This impairment by comparison with the minimum valve overlap drops still further with increasing engine speed, and a clear increase to virtually the target intermediate pressure can be seen only as of 1600 rpm. The torque with valve overlap can be boosted slightly even at 1000 rpm with the dual-volute VTG and scroll separation. The increase grows with increasing engine speed, until, ultimately, the target intermediate pressure is reached or clearly overshoot at 1600 rpm. The curves of the air

demand show the impressive increase to optimum values at the relevant engine speeds on the basis of the variant dual-volute VTG with scroll separation and valve overlap.

The curve of the residual gas content is similar. Whilst the residual gas content is only able to be effectively reduced as of 1600 rpm with the single-scroll VTG and valve overlap, this is possible at all engine speeds with the dual-volute VTG. The reductions achieved indicate operation virtually free of residual gas. This shows the effect of scroll separation through to the guide blades in the turbine most impressively. There is an increase in turbine output owing to the use of the kinetic energy of the exhaust gas up to approx. 1400 rpm at low engine speeds.

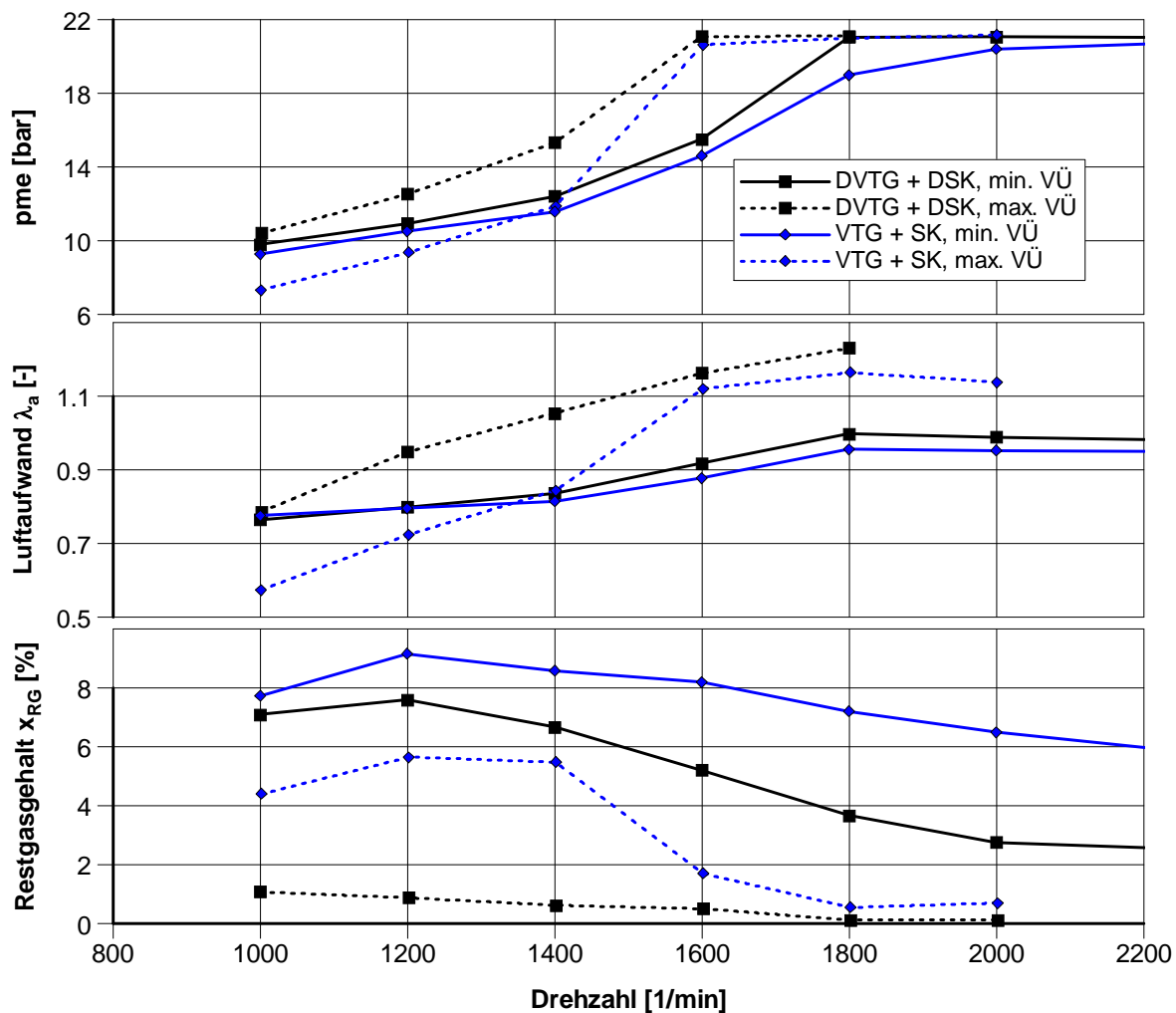

Figure 5.3.1: Engine characteristic parameters of the turbocharger variants investigated at full load with minimum and maximum valve overlap at low engine speeds

A consideration of the pressure curves or mass flow values of the dual-volute VTG at 1600 rpm at various times in Figure 5.3.2 clearly indicates the interrelationships. The dynamic flushing gradient (upper part-diagram) clearly shows the effect of a valve overlap (VÜ). The dynamic flushing gradient is negative in the majority during the area with minimum valve overlap (highlighted in dark gray), this resulting in a residual gas content of 5.2 % (Figure 5.3.1). By contrast, with maximum valve overlap (highlighted in light gray), a positive flushing gradient can be seen primarily in the area of large, open valve cross-sections, this resulting in a residual gas content of approx. 0.5 % (Figure 5.3.1).

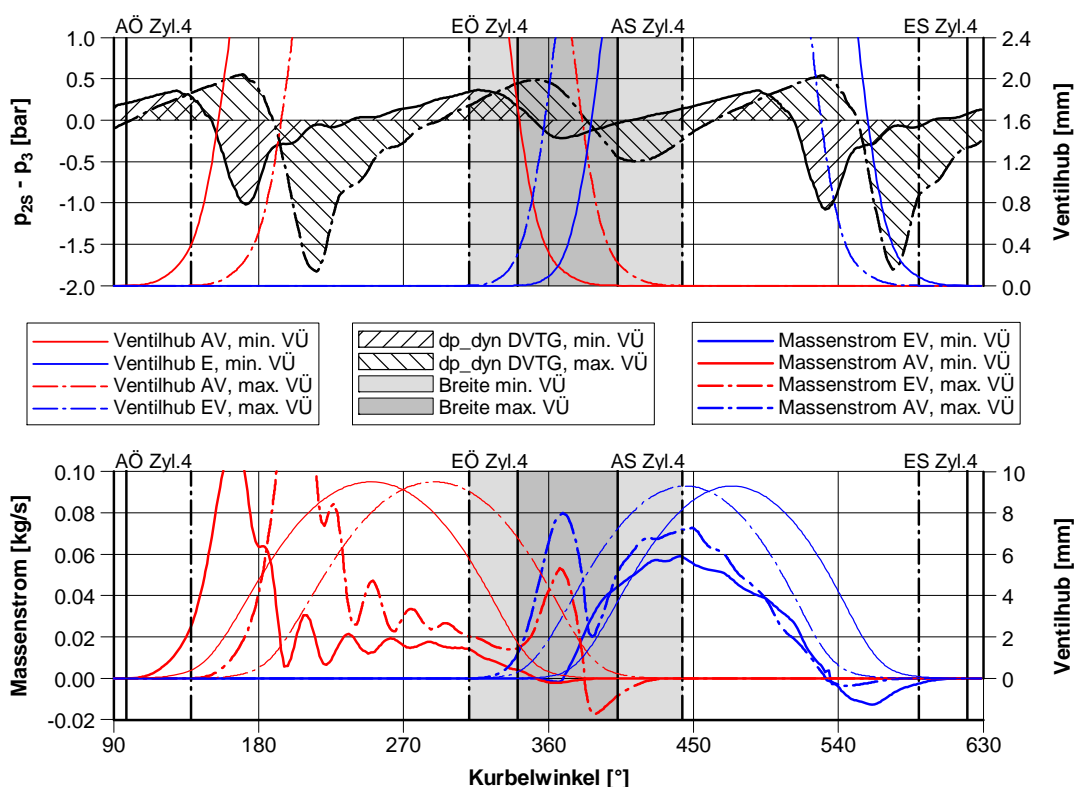

Figure 5.3.2: Charge cycle at 1600 rpm of the dual-volute VTG with minimum and maximum valve overlap

The lower part-diagram shows the mass flow values across the inlet and outlet valves owing to the pressure differences. With minimum valve overlap, no rectified mass flow values can be seen during the valve overlap phase and this results in no or only slight residual gas scavenging. By contrast, with maximum valve overlap, there is a simultaneous, rectified rise in outlet and inlet mass flow, indicated by a flushing charge cycle and the associated residual gas flushing. The outlet mass flow follows the dynamic flushing gradient which becomes more negative towards the end of the overlap phase, consequently indicating a low flow-back from the exhaust gas

manifold to the cylinder. A shorter control width of the outlet camshaft would be advantageous in order to avoid flow-back and thus further-optimize the flushing charge cycle.

The effects of operation of the dual-volute VTG with valve overlap in the compressor characteristic map are shown in Figure 5.3.3 which follows.

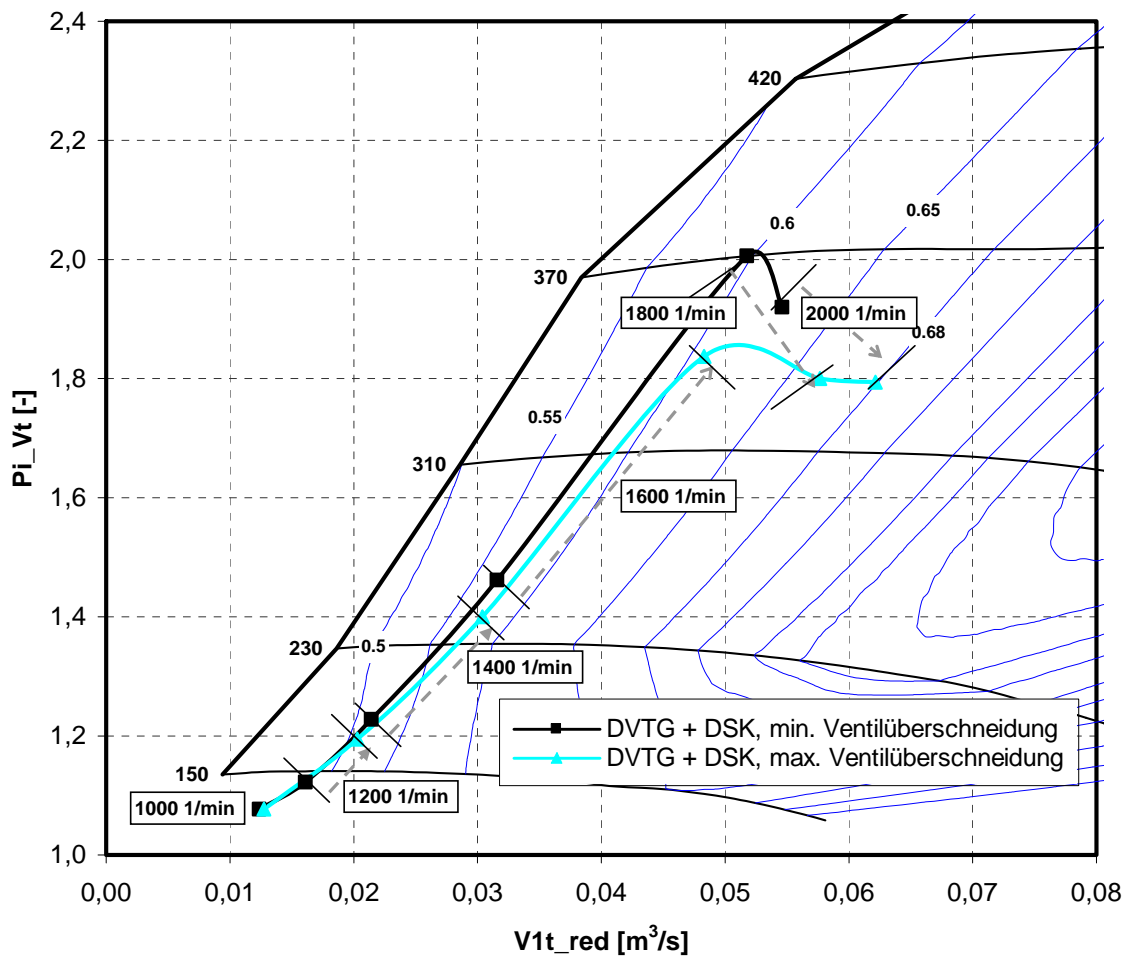

Figure 5.3.3: Full-load operating curves of the dual-volute VTG with minimum and maximum valve overlap in the compressor characteristic map at 1000-2000 rpm

Here, it can be seen how the operating points in the compressor characteristic map shift towards higher flow rates owing to the valve overlap. The shifts also include intermediate pressure increases in the lower engine-speed range up to and including 1600 rpm. As of 1800 rpm, the compressor pressure ratio can be lowered and the throughput can be increased at the same intermediate pressures. This is a known phenomenon of the flushing charge cycle. The operating points continue to shift towards better compressor efficiencies, leading to a lower required

turbine output. This causes a reduction in the pressure build-up demand and the exhaust gas pressure upstream of the turbine. This indicates the advantage of variable turbine geometry by comparison with fixed-geometry turbochargers since they allow a lower exhaust-gas pressure upstream of the turbine instead of blow-off control by adaptation of the guide blades.

Summary and outlook

Within the framework of BorgWarner's activities to improve the engine operating behavior of turbocharged DI-SI engines, this article analyzes a combination of variable turbine geometry and dual-volute turbine housing. The engine investigations were conducted in cooperation with the TurboAcademy at Mannheim University.

By comparison with a single-scroll VTG with congestion-type and ignition-sequence exhaust gas manifold, the dual-volute VTG clearly shows the potential to improve the overall engine and turbocharging system.

The results substantiate various mechanisms and their advantageous effects:

- A clear increase in torque virtually only using the kinetic energy is possible in the case of scroll-separated turbine housings and exhaust gas manifolds up to 1400 rpm (with the same series size and same variability of the valve timing gear).
- A clear potential for residual gas reduction can be seen in the entire engine-speed range, in particular at low and moderate engine speeds.
- The dual-volute VTG is the logical step to "residual gas avoidance" instead of having to flush out this residual gas.
- The clear reduction in exhaust gas back-pressure at moderate engine speeds leads to a significant reduction in charge cycle losses.
- Integration of scroll connection allows the exhaust gas back-pressure to be clearly reduced at moderate to high engine speeds.
- Expansion or compliance with the $\lambda = 1$ operating range is possible owing to scroll separation.

Possible steps for future further developments can be derived from these results:

- Analysis of the potential for reducing the valve timing gear variabilities

- Potential for reducing the turbine size in the case of dual-volute VTGs for an improvement in low-end torque with simultaneous use of scroll connection in the rated output range (surge-congestion switchover)
- Potential to improve the low-end torque in the case of integration of new developments in the area of the guide blades and the turbine (rotor geometries, aerodynamic housings)
- Potential for utilization of scroll connection for further degrees of freedom in the overall characteristic map area

The variability of the turbocharger in conjunction with variable valve timing will be an important part of future developments in the case of modern, turbocharged DI-SI engines. BorgWarner, as the technology leader for the use of VTG turbochargers on SI engines, in addition to continuing developments, can make its contribution in this case with its know-how for fast phase adjusters with CTA (Cam Torque Actuated) technology.

Based on the findings obtained, BorgWarner will continue to work in-depth on this technology in order to be able to offer solutions for future, high-performance, low-emission and, above all, low-consumption SI engines.

Amerika

BorgWarner Turbo Systems

3800 Automation Avenue
Auburn Hills, MI 48326/USA
Telefon: ++ 1248 754 9600
Telefax: ++ 1248 754 9397

BorgWarner Turbo Systems

P.O. Box 15075
Asheville, NC 28813/USA
Telefon: ++ 1828 684 40 00
Telefax: ++ 1828 684 41 14

BorgWarner Brasil Ltda.

Estrada da Rhodia Km 15
P.O. Box 6540
13084-970 Campinas-SP/Brasil
Telefon: ++ 55 19 37 87 57 00
Telefax: ++ 55 19 37 87 57 01

Europa

BorgWarner Turbo Systems GmbH

Marnheimer Straße 85/87
67292 Kirchheimbolanden/Germany
Telefon: ++ 49 (0)63 52 4 03-0
Telefax: ++ 49 (0)63 52 4 03-18 66

**BorgWarner Ltd.
Turbo Systems Division**

Bradford BD4 6SE
West Yorkshire/UK
Telefon: ++ 44 12 74 68 49 15
Telefax: ++ 44 12 74 68 96 71

BorgWarner France SAS

23 bis, avenue de l'Europe
78400 Chatou/Frankreich
Telefon: ++ 33 1 3015 94 44
Telefax: ++ 33 1 3015 94 40

BorgWarner Turbo Systems

Poland Sp. z o.o.
Jasionka 950
36-002 Rzeszów/Poland
Telefon: ++ 48 1 78 50 88 00
Telefax: ++ 48 1 78 50 88 34

BorgWarner Turbo Systems Kft.

Táncsics Mihály út 111.
H-2840 Oroszlány/Ungarn
Telefon: ++ 36 34 562-300
Telefax: ++ 36 34 562-301

Asien

BorgWarner Turbo & Emissions Systems

Shin-Yokohama Turbo Branch
Sumitomo Fudosan
Shin-Yokohama Bldg.10F
2-5-5, Shin-Yokoyama, Kouhoku-ku
Yokohama-shi, Kanagawa
222-0033 Japan
Telefon: ++ 8145 470 6850
Telefax: ++ 8145 470 6811

**BorgWarner Automotive
Components (Ningbo) Co., Ltd.
Turbo & Emissions Systems**

No.188, Jingu Zhong Rd. (West)
Yinzhou District
Ningbo P.R. China 315104
Telefon: ++ 86 (0)574-8819-0930
Telefax: ++ 86 (0)574-8302-5883

SeohanWarner Turbo Systems Ltd.

Eoyeon-Hansan Industrial Park
893-1, Eoyeon-ri, Cheongbuk-myeon
Pyongtaek-shi, Kyonggi-do
451-833 Korea
Telefon: ++ 82 (0)31-680-00 01
Telefax: ++ 83 (0)31-683-929

www.borgwarner.com



feel good about driving